

**This electronic collection of documents is provided
for the convenience of the user
and is Not a Certified Document –**

**The documents contained herein were originally issued
and sealed by the individuals whose names and license
numbers appear on each page, on the dates appearing
with their signature on that page.**

**This file or an individual page
shall not be considered a certified document.**

TIP PROJECT: HB-0030

CONTRACT: DN01129

See Sheet 1A For Index of Sheets
See Sheet 1B For Conventional Symbols
See RW Sheet Series For Survey Control

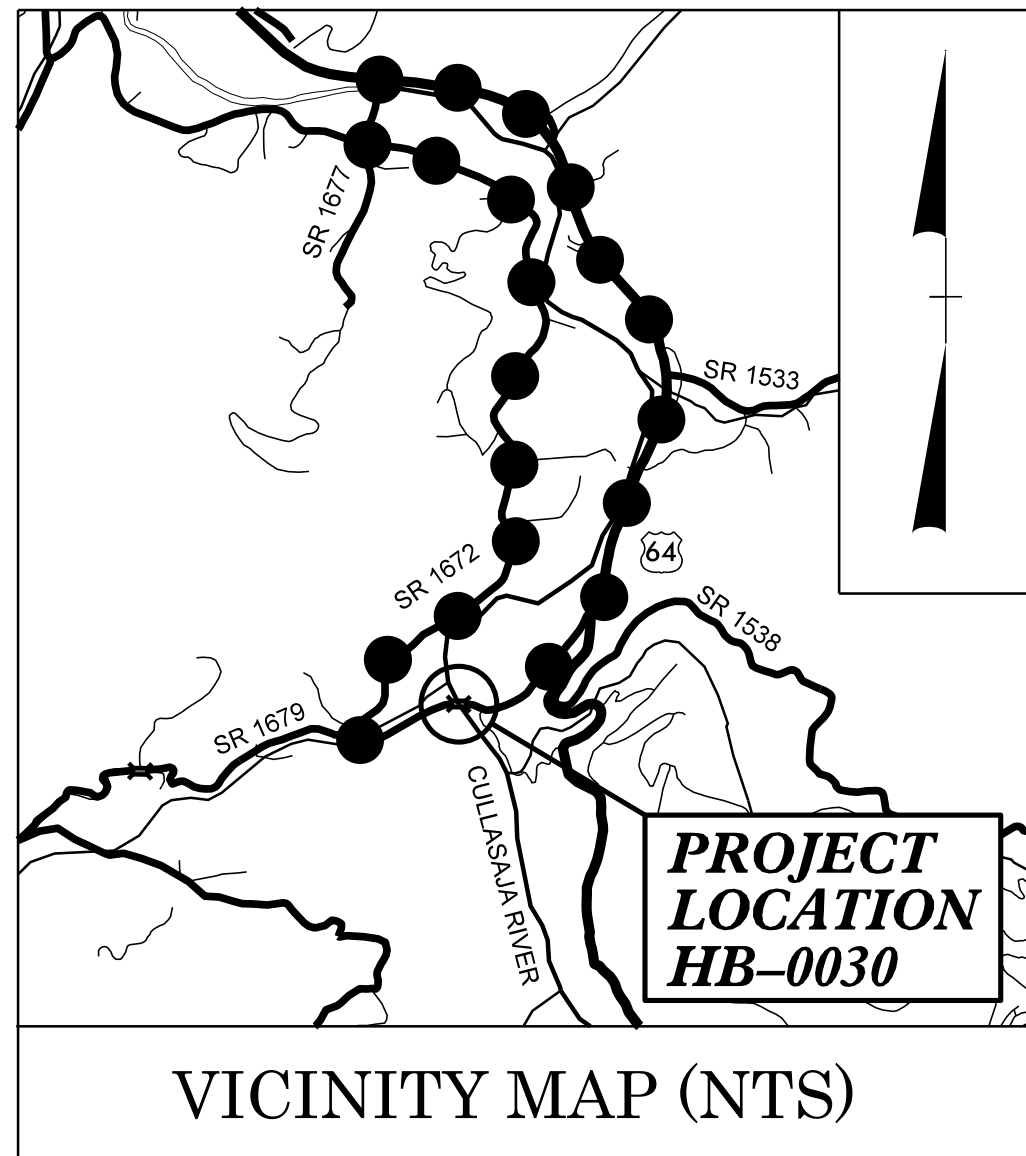

STATE OF NORTH CAROLINA DIVISION OF HIGHWAYS

MACON COUNTY

LOCATION: *REPLACE BRIDGE NO. 550055 ON SR 1679 (PEEKS CREEK RD)
OVER CULLASAJA RIVER*

TYPE OF WORK: *GRADING, DRAINAGE, PAVING, STRUCTURE*

STATE	STATE PROJECT REFERENCE NO.	SHEET NO.	TOTAL SHEETS
N.C.	HB-0030	1	
STATE PROJ. NO.	F. A. PROJ. NO.	DESCRIPTION	
50647.1.1	N/A	P.E.	
50647.2.1	N/A	R/W	
50647.2.2	N/A	UTIL	
50647.3.1	N/A	CONST	

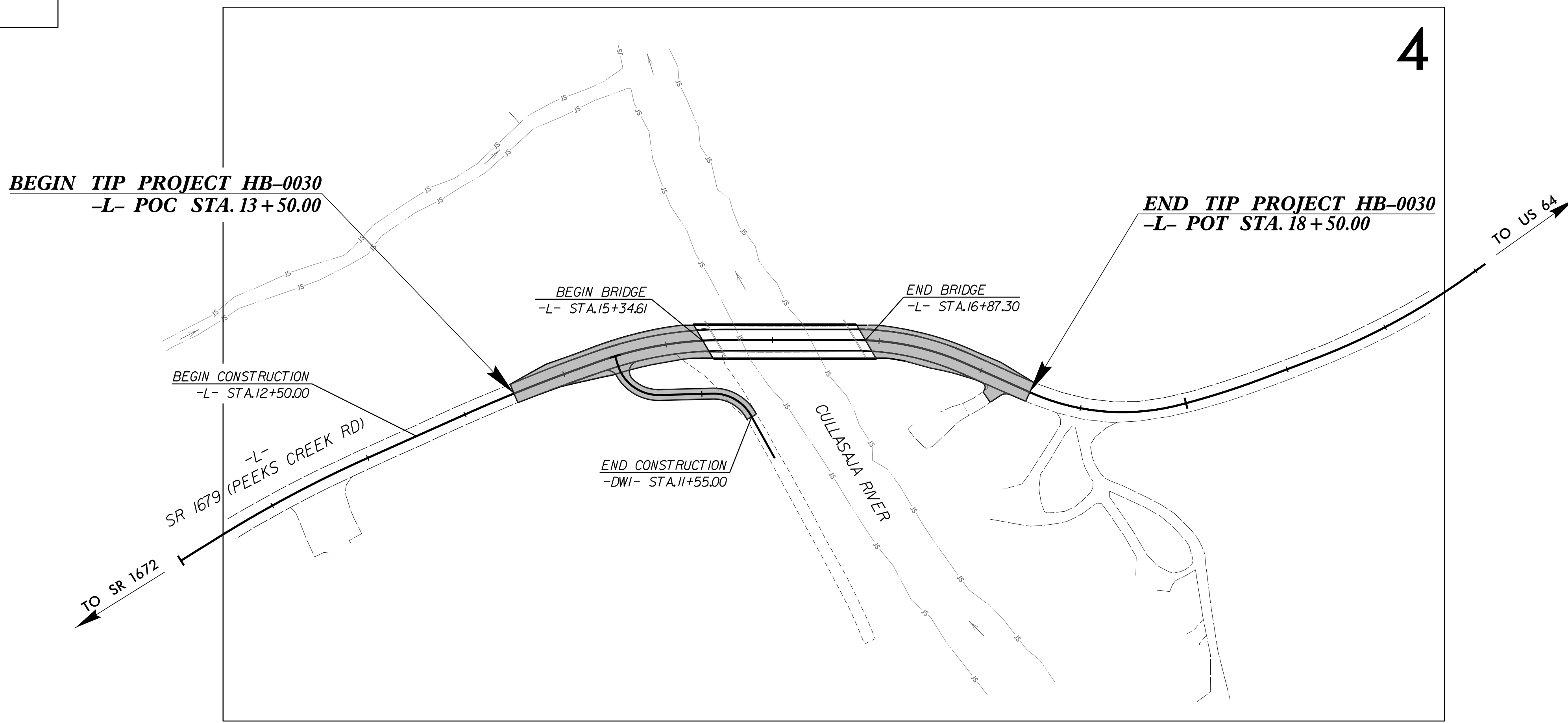
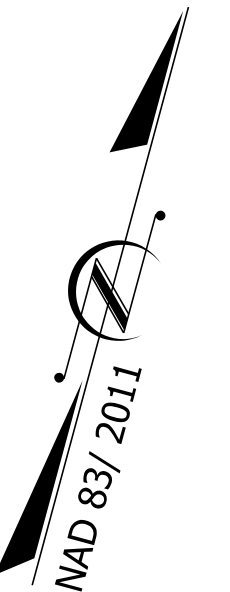

4

THERE IS NO CONTROL OF ACCESS ON THIS PROJECT.

DOCUMENT NOT CONSIDERED FINAL
UNLESS ALL SIGNATURES COMPLETED

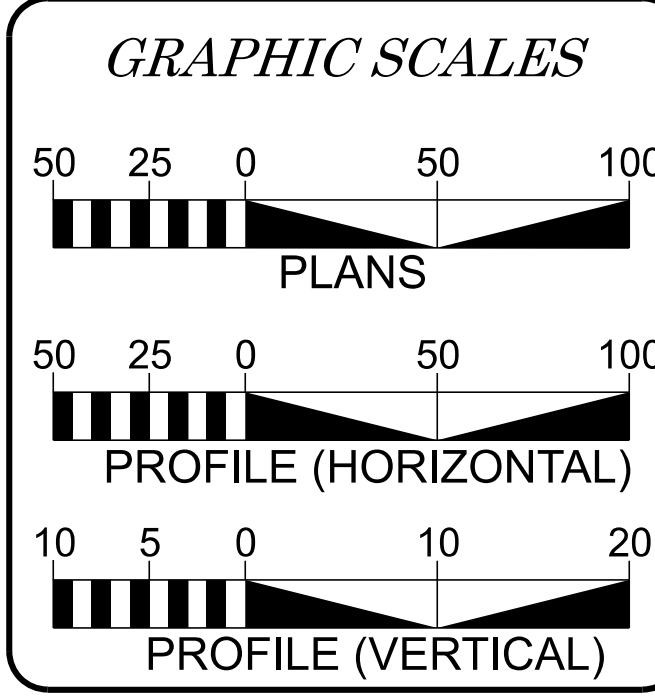

DESIGN DATA

ADT 2025 =	174
ADT 2045 =	289
K =	%
D =	%
T =	% *
V =	40 MPH
* TTST =	DUAL
FUNC CLASS =	LOCAL
SUB-REGIONAL TIER	

PROJECT LENGTH

LENGTH ROADWAY TIP PROJECT HB-0030	0.066 MI
LENGTH STRUCTURE TIP PROJECT HB-0030	0.029 MI
TOTAL LENGTH OF TIP PROJECT HB-0030	0.095 MI

PLANS PREPARED BY:

DRMP, INC.
5808 FARINGTON PLACE, SUITE 100
RALEIGH, NORTH CAROLINA 27609
(919) 872-5115
NC LICENSE NO. F-1524

FOR
NCDOT HIGHWAY DIVISION 14

2024 STANDARD SPECIFICATIONS

RIGHT OF WAY DATE:
OCTOBER 11, 2024

LETTING DATE:
DECEMBER 9, 2025

CHRISTOPHER K. HAIRE, PE
PROJECT ENGINEER

TIMOTHY A. KLOTZ, PE
PROJECT DESIGN ENGINEER

JARED M. BOND, PE
NCDOT PROJECT MANAGER

HYDRAULICS ENGINEER
10/7/2025

DocuSigned by:
Ryan P. Mitchell
SIGNATURE: P.E.

ROADWAY DESIGN ENGINEER
10/7/2025

DocuSigned by:
Timothy A. Klotz
SIGNATURE: P.E.

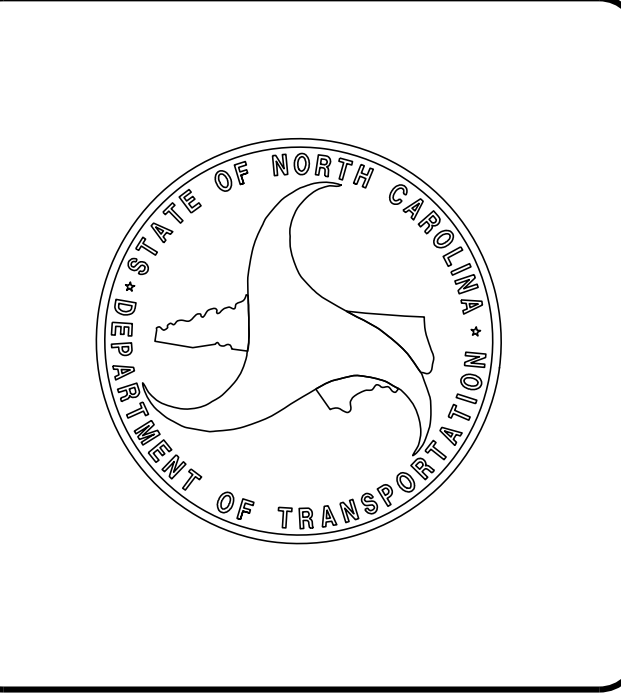

HB-0030
IA
 NORTH CAROLINA
 DEPARTMENT OF TRANSPORTATION
 MACON COUNTY

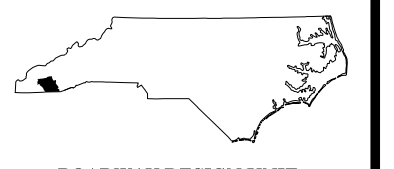

ROADWAY DESIGN UNIT
 ROADWAY DESIGN
 ENGINEER

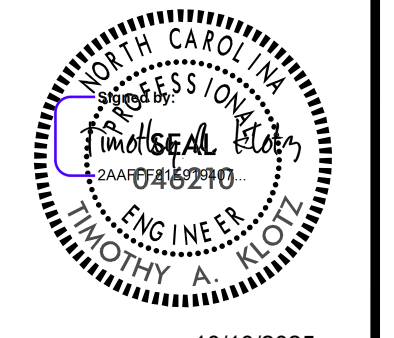

10/10/2025

GENERAL NOTES: 2024 SPECIFICATIONS
 EFFECTIVE: 01-16-2024
 REVISED:

EFF. 01-16-2024
 REV.

2024 ROADWAY ENGLISH STANDARD DRAWINGS

The following Roadway Standards as appear in "Roadway Standard Drawings" Contracts Standards and Development Unit - N. C. Department of Transportation - Raleigh, N. C., Dated January 16, 2024 are applicable to this project and by reference hereby are considered a part of these plans:

STD.NO.	TITLE
DIVISION 2 - EARTHWORK	
200.02	Method of Clearing - Method II
225.02	Guide for Grading Subgrade - Secondary and Local
225.04	Method of Obtaining Superelevation - Two Lane Pavement

DIVISION 3 - PIPE CULVERTS	
300.01	Method of Pipe Installation (Use Details in Lieu of Standards for Sheet 2 of 2)
310.10	Driveway Pipe Construction

DIVISION 4 - MAJOR STRUCTURES	
423.01	Bridge Approach Fills - Type 1 Approach Fill for Bridge Abutment

DIVISION 5 - SUBGRADE, BASES AND SHOULDERS	
560.01	Method of Shoulder Construction - High Side of Superelevated Curve - Method I

DIVISION 8 - INCIDENTALS	
815.02	Subsurface Drain
840.00	Concrete Base Pad for Drainage Structures
840.25	Anchorage for Frames - Brick or Concrete or Precast
840.29	Frames and Narrow Slot Flat Grates
840.35	Traffic Bearing Grated Drop Inlet - for Cast Iron Double Frame and Grates
840.46	Traffic Bearing Precast Drainage Structure
840.66	Drainage Structure Steps
846.01	Concrete Curb, Gutter and Curb & Gutter
846.04	Drop Inlet Installation in Shoulder Berm Gutter
862.01	Guardrail Placement (Use Details in Lieu of Standards for Sheets 4 and 6 of 15)
862.02	Guardrail Installation
862.03	Structure Anchor Units
876.01	Rip Rap in Channels and Ditches
876.02	Guide for Rip Rap at Pipe Outlets
876.04	Drainage Ditches with Class 'B' Rip Rap

INDEX OF SHEETS

SHEET NUMBER	SHEET
1	TITLE SHEET
1A	INDEX OF SHEETS, GENERAL NOTES, AND LIST OF STANDARDS
1B	CONVENTIONAL SYMBOLS
2A-1 THRU 2A-2	PAVEMENT SCHEDULE AND TYPICAL SECTIONS
2B-1	PAVED SHOULDER AND GUARDRAIL DETAIL
2C-1	TYPE III SHOP CURVED STRUCTURE ANCHOR UNIT
2C-2	GUARDRAIL AT TWO LANE - TWO WAY LOCATIONS
2C-3	GUARDRAIL PLACEMENT - DETAIL OF BEGINNING OF GUARDRAIL IN CUT OR FILL SECTION
2C-4	METHOD OF PIPE INSTALLATION - RIGID PIPE
3B-1	ROADWAY SUMMARIES
3D-1	DRAINAGE SUMMARIES
3G-1	GEOTECHNICAL SUMMARIES
4 THRU 5	PLAN AND PROFILE SHEETS
RW-01 THRU RW-04	SURVEY CONTROL, EXISTING CENTERLINES, RIGHT OF WAY, EASEMENT AND PROPERTY TIES
TMP-1 THRU TMP-4	TRAFFIC MANAGEMENT PLANS
PMP-1 THRU PMP-2	PAVEMENT MARKING PLANS
EC-1 THRU EC-4	EROSION CONTROL PLANS
RF-1	REFORESTATION PLANS
SIGN-1 THRU SIGN-3	SIGNING PLANS
X-1	CROSS-SECTION SUMMARY SHEET
X-2 THRU X-11	CROSS-SECTIONS
S-1 THRU S-27	STRUCTURE PLANS

GRADING AND SURFACING:

THE GRADE LINES SHOWN DENOTE THE FINISHED ELEVATION OF THE PROPOSED SURFACING AT GRADE POINTS SHOWN ON THE TYPICAL SECTIONS. GRADE LINES MAY BE ADJUSTED AT THEIR BEGINNING AND ENDING AND AT STRUCTURES AS DIRECTED BY THE ENGINEER IN ORDER TO SECURE A PROPER TIE-IN.

CLEARING:

CLEARING ON THIS PROJECT SHALL BE PERFORMED TO THE LIMITS ESTABLISHED BY METHOD II.

SUPERELEVATION:

ALL CURVES ON THIS PROJECT SHALL BE SUPERELEVATED IN ACCORDANCE WITH STD. NO. 225.04 USING THE RATE OF SUPERELEVATION AND RUNOFF SHOWN ON THE PLANS. SUPERELEVATION IS TO BE REVOLVED ABOUT THE GRADE POINTS SHOWN ON THE TYPICAL SECTIONS.

SHOULDER CONSTRUCTION:

ASPHALT, EARTH, AND CONCRETE SHOULDER CONSTRUCTION ON THE HIGH SIDE OF SUPERELEVATED CURVES SHALL BE IN ACCORDANCE WITH STD. NO. 560.01

SIDE ROADS:

THE CONTRACTOR WILL BE REQUIRED TO DO ALL NECESSARY WORK TO PROVIDE SUITABLE CONNECTIONS WITH ALL ROADS, STREETS, AND DRIVES ENTERING THIS PROJECT. THIS WORK WILL BE PAID FOR AT THE CONTRACT UNIT PRICE FOR THE PARTICULAR ITEMS INVOLVED.

SUBSURFACE DRAINS:

SUBSURFACE DRAINS SHALL BE CONSTRUCTED IN ACCORDANCE WITH STD. NO. 815.02 AT LOCATIONS DIRECTED BY THE ENGINEER.

GUARDRAIL:

THE GUARDRAIL LOCATIONS SHOWN ON THE PLANS MAY BE ADJUSTED DURING CONSTRUCTION AS DIRECTED BY THE ENGINEER. THE CONTRACTOR SHOULD CONSULT WITH THE ENGINEER PRIOR TO ORDERING GUARDRAIL MATERIAL.

END BENTS:

THE ENGINEER SHALL CHECK THE STRUCTURE END BENT PLANS, DETAILS, AND CROSS-SECTION PRIOR TO SETTING OF THE SLOPE STAKES FOR THE EMBANKMENT OR EXCAVATION APPROACHING A BRIDGE.

UTILITIES:

UTILITY OWNERS ON THIS PROJECT ARE DUKE ENERGEY AND FRONTIER

ANY RELOCATION OF EXISTING UTILITIES WILL BE ACCOMPLISHED BY OTHERS.

RIGHT-OF-WAY MARKERS:

ALL RIGHT-OF-WAY MARKERS ON THIS PROJECT SHALL BE PLACED BY OTHERS.

REVISIONS

STATE OF NORTH CAROLINA, DIVISION OF HIGHWAYS CONVENTIONAL PLAN SHEET SYMBOLS

Note: Not to Scale

BOUNDARIES AND PROPERTY:

State Line	-----	
County Line	-----	
Township Line	-----	
City Line	-----	
Reservation Line	-----	
Property Line	-----	
Existing Iron Pin (EIP)	-----	⊙
Computed Property Corner	-----	X
Existing Concrete Monument (ECM)	-----	⊞
Parcel / Sequence Number	-----	(23)
Existing Fence Line	-x-x-x-	
Proposed Woven Wire Fence	-----	○
Proposed Chain Link Fence	-----	□
Proposed Barbed Wire Fence	-----	◇
Existing Wetland Boundary	-----	MLB
Proposed Wetland Boundary	-----	MLB
Existing Endangered Animal Boundary	-----	EAB
Existing Endangered Plant Boundary	-----	EPB
Existing Historic Property Boundary	-----	HPB
Known Contamination Area: Soil	-----	
Potential Contamination Area: Soil	-----	
Known Contamination Area: Water	-----	
Potential Contamination Area: Water	-----	
Contaminated Site: Known or Potential	-----	☠ ☢

BUILDINGS AND OTHER CULTURE:

Gas Pump Vent or U/G Tank Cap	-----	○
Sign	-----	⊙
Well	-----	⊙
Small Mine	-----	⊗
Foundation	-----	⊞
Area Outline	-----	⊞
Cemetery	-----	⊞
Building	-----	⊞
School	-----	⊞
Church	-----	⊞
Dam	-----	⊞

HYDROLOGY:

Stream or Body of Water	-----	
Hydro, Pool or Reservoir	-----	
Jurisdictional Stream	-----	JS
Buffer Zone 1	-----	BZ 1
Buffer Zone 2	-----	BZ 2
Flow Arrow	-----	←
Disappearing Stream	-----	→
Spring	-----	⊙
Wetland	-----	⊙
Proposed Lateral, Tail, Head Ditch	-----	⊙
False Sump	-----	⊙

RAILROADS:

Standard Gauge	-----	CSX TRANSPORTATION
RR Signal Milepost	-----	MILEPOST 35
Switch	-----	SWITCH
RR Abandoned	-----	
RR Dismantled	-----	

RIGHT OF WAY & PROJECT CONTROL:

Primary Horiz Control Point	-----	⬡
Primary Horiz and Vert Control Point	-----	⬢
Secondary Horiz and Vert Control Point	-----	⬢
Vertical Benchmark	-----	⊞
Existing Right of Way Monument	-----	⬡
Proposed Right of Way Monument (Rebar and Cap)	-----	⬢
Proposed Right of Way Monument (Concrete)	-----	⬢
Existing Permanent Easement Monument	-----	⬢
Proposed Permanent Easement Monument (Rebar and Cap)	-----	⬢
Existing C/A Monument	-----	⬢
Proposed C/A Monument (Rebar and Cap)	-----	⬢
Proposed C/A Monument (Concrete)	-----	⬢
Existing Right of Way Line	-----	⬢
Proposed Right of Way Line	-----	⬢
Existing Control of Access Line	-----	⬢
Proposed Control of Access Line	-----	⬢
Proposed ROW and CA Line	-----	⬢
Existing Easement Line	-----	E
Proposed Temporary Construction Easement	-----	E
Proposed Temporary Drainage Easement	-----	TDE
Proposed Permanent Drainage Easement	-----	PDE
Proposed Permanent Drainage/Utility Easement	-----	DUE
Proposed Permanent Utility Easement	-----	PUE
Proposed Temporary Utility Easement	-----	TUE
Proposed Aerial Utility Easement	-----	AUE

ROADS AND RELATED FEATURES:

Existing Edge of Pavement	-----	
Existing Curb	-----	
Proposed Slope Stakes Cut	-----	C
Proposed Slope Stakes Fill	-----	F
Proposed Curb Ramp	-----	CR
Existing Metal Guardrail	-----	
Proposed Guardrail	-----	
Existing Cable Guiderail	-----	
Proposed Cable Guiderail	-----	
Equality Symbol	-----	⊕
Pavement Removal	-----	⊕
VEGETATION:		
Single Tree	-----	⊙
Single Shrub	-----	⊙
Hedge	-----	⊙

Woods Line	-----	
Orchard	-----	⊙
Vineyard	-----	Vineyard

EXISTING STRUCTURES:

MAJOR:		
Bridge, Tunnel or Box Culvert	-----	CONC
Bridge Wing Wall, Head Wall and End Wall	-----	CONC WW
MINOR:		
Head and End Wall	-----	CONC HW
Pipe Culvert	-----	
Footbridge	-----	
Drainage Box: Catch Basin, DI or JB	-----	CB
Paved Ditch Gutter	-----	
Storm Sewer Manhole	-----	⊙
Storm Sewer	-----	S

UTILITIES:

* SUE - Subsurface Utility Engineering
LOS - Level of Service - A,B,C or D (Accuracy)

POWER:		
Existing Power Pole	-----	⊙
Proposed Power Pole	-----	⊙
Existing Joint Use Pole	-----	⊙
Proposed Joint Use Pole	-----	⊙
Power Manhole	-----	⊙
Power Line Tower	-----	⊙
Power Transformer	-----	⊙
U/G Power Cable Hand Hole	-----	⊙
H-Frame Pole	-----	⊙
U/G Power Line Test Hole (SUE - LOS A)*	-----	⊙
U/G Power Line (SUE - LOS B)*	-----	P
U/G Power Line (SUE - LOS C)*	-----	P
U/G Power Line (SUE - LOS D)*	-----	P

TELEPHONE:

Existing Telephone Pole	-----	⊙
Proposed Telephone Pole	-----	⊙
Telephone Manhole	-----	⊙
Telephone Pedestal	-----	⊙
Telephone Cell Tower	-----	⊙
U/G Telephone Cable Hand Hole	-----	⊙
U/G Telephone Test Hole (SUE - LOS A)*	-----	⊙
U/G Telephone Cable (SUE - LOS B)*	-----	T
U/G Telephone Cable (SUE - LOS C)*	-----	T
U/G Telephone Cable (SUE - LOS D)*	-----	T
U/G Telephone Conduit (SUE - LOS B)*	-----	TC
U/G Telephone Conduit (SUE - LOS C)*	-----	TC
U/G Telephone Conduit (SUE - LOS D)*	-----	TC
U/G Fiber Optics Cable (SUE - LOS B)*	-----	T FO
U/G Fiber Optics Cable (SUE - LOS C)*	-----	T FO
U/G Fiber Optics Cable (SUE - LOS D)*	-----	T FO

WATER:

Water Manhole	-----	⊙
Water Meter	-----	⊙
Water Valve	-----	⊙
Water Hydrant	-----	⊙
U/G Water Line Test Hole (SUE - LOS A)*	-----	⊙
U/G Water Line (SUE - LOS B)*	-----	W
U/G Water Line (SUE - LOS C)*	-----	W
U/G Water Line (SUE - LOS D)*	-----	W
Above Ground Water Line	-----	A/G Water

TV:

TV Pedestal	-----	⊙
TV Tower	-----	⊙
U/G TV Cable Hand Hole	-----	⊙
U/G TV Test Hole (SUE - LOS A)*	-----	⊙
U/G TV Cable (SUE - LOS B)*	-----	TV
U/G TV Cable (SUE - LOS C)*	-----	TV
U/G TV Cable (SUE - LOS D)*	-----	TV
U/G Fiber Optic Cable (SUE - LOS B)*	-----	TV FO
U/G Fiber Optic Cable (SUE - LOS C)*	-----	TV FO
U/G Fiber Optic Cable (SUE - LOS D)*	-----	TV FO

GAS:

Gas Valve	-----	⊙
Gas Meter	-----	⊙
U/G Gas Line Test Hole (SUE - LOS A)*	-----	⊙
U/G Gas Line (SUE - LOS B)*	-----	G
U/G Gas Line (SUE - LOS C)*	-----	G
U/G Gas Line (SUE - LOS D)*	-----	G
Above Ground Gas Line	-----	A/G Gas

SANITARY SEWER:

Sanitary Sewer Manhole	-----	⊙
Sanitary Sewer Cleanout	-----	⊙
U/G Sanitary Sewer Line	-----	SS
Above Ground Sanitary Sewer	-----	A/G Sanitary Sewer
SS Force Main Line Test Hole (SUE - LOS A)*	-----	⊙
SS Force Main Line (SUE - LOS B)*	-----	FSS
SS Force Main Line (SUE - LOS C)*	-----	FSS
SS Force Main Line (SUE - LOS D)*	-----	FSS

MISCELLANEOUS:

Utility Pole	-----	⊙
Utility Pole with Base	-----	⊙
Utility Located Object	-----	⊙
Utility Traffic Signal Box	-----	⊙
Utility Unknown U/G Line (SUE - LOS B)*	-----	⊙
U/G Tank; Water, Gas, Oil	-----	⊙
Underground Storage Tank, Approx. Loc.	-----	UST
A/G Tank; Water, Gas, Oil	-----	⊙
Geoenvironmental Boring	-----	⊙
Abandoned According to Utility Records	-----	AATUR
End of Information	-----	E.O.I.

FINAL PAVEMENT SCHEDULE
(PAVEMENT DESIGN DATED: 8/8/2024)

C1	PROP. APPROX. 1.5" ASPHALT CONCRETE SURFACE COURSE, TYPE S9.5B, AT AN AVERAGE RATE OF 165 LBS. PER SQ. YD.	R1	SHOULDER BERM GUTTER.
C2	PROP. APPROX. 3" ASPHALT CONCRETE SURFACE COURSE, TYPE S9.5B, AT AN AVERAGE RATE OF 165 LBS. PER SQ. YD. IN EACH OF TWO LAYERS.	T	EARTH MATERIAL.
C3	PROP. VAR. DEPTH ASPHALT CONCRETE SURFACE COURSE, TYPE S9.5B, AT AN AVERAGE RATE OF 110 LBS. PER SQ. YARD PER 1" DEPTH TO BE PLACED IN LAYERS NOT TO EXCEED 1.5" IN DEPTH.	U	EXISTING PAVEMENT.
E1	PROP. APPROX. 4" ASPHALT CONCRETE BASE COURSE, TYPE B25.0C, AT AN AVERAGE RATE OF 456 LBS. PER SQ. YD.	V1	MILLING ASPHALT PAVEMENT, 1.5" DEPTH.
E2	PROP. VAR. DEPTH ASPHALT CONCRETE BASE COURSE, TYPE B25.0C, AT AN AVERAGE RATE OF 114 LBS. PER SQ. YARD PER 1" DEPTH, TO BE PLACED IN LAYERS NOT TO EXCEED 5.5" IN DEPTH OR LESS THAN 3"	V2	INCIDENTAL MILLING (VARIABLE DEPTH 0" TO 1.5" DEPTH).
J1	PROP. 6" AGGREGATE BASE COURSE.	W1	VARIABLE DEPTH ASPHALT PAVEMENT (SEE STANDARD WEDGING DETAIL).
J2	PROP. 8" AGGREGATE BASE COURSE.		

NOTE: PAVEMENT EDGE SLOPES ARE 1:1 UNLESS SHOWN OTHERWISE

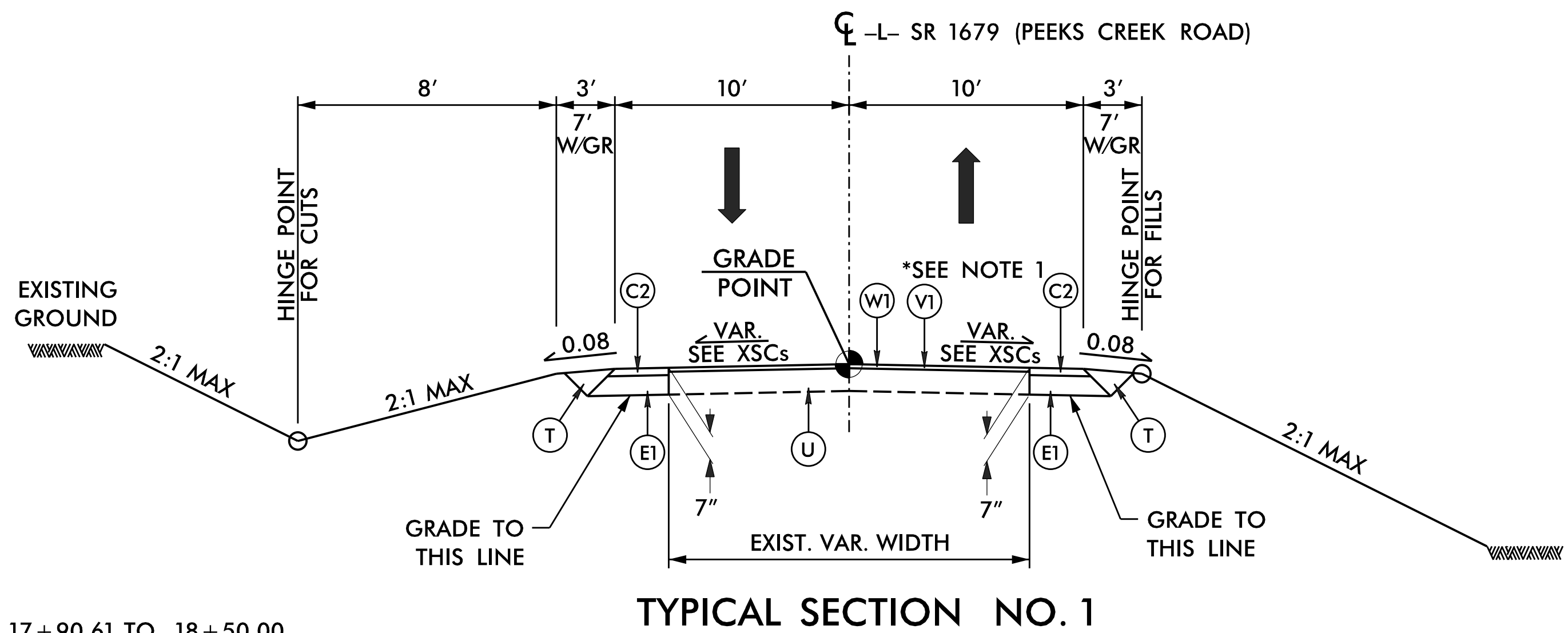

TYPICAL SECTION NO. 1

USE TYPICAL SECTION NO. 1
-L- STA. 13+50.00 TO 14+85.00
-L- STA. 17+90.61 TO 18+50.00

- NOTES:
- 1.5" MILLING FROM -L- STA. 17+90.61 TO 18+50.00
 - SEE SHEET 2B-1 FOR PAVED SHOULDER AND GUARDRAIL LOCATIONS

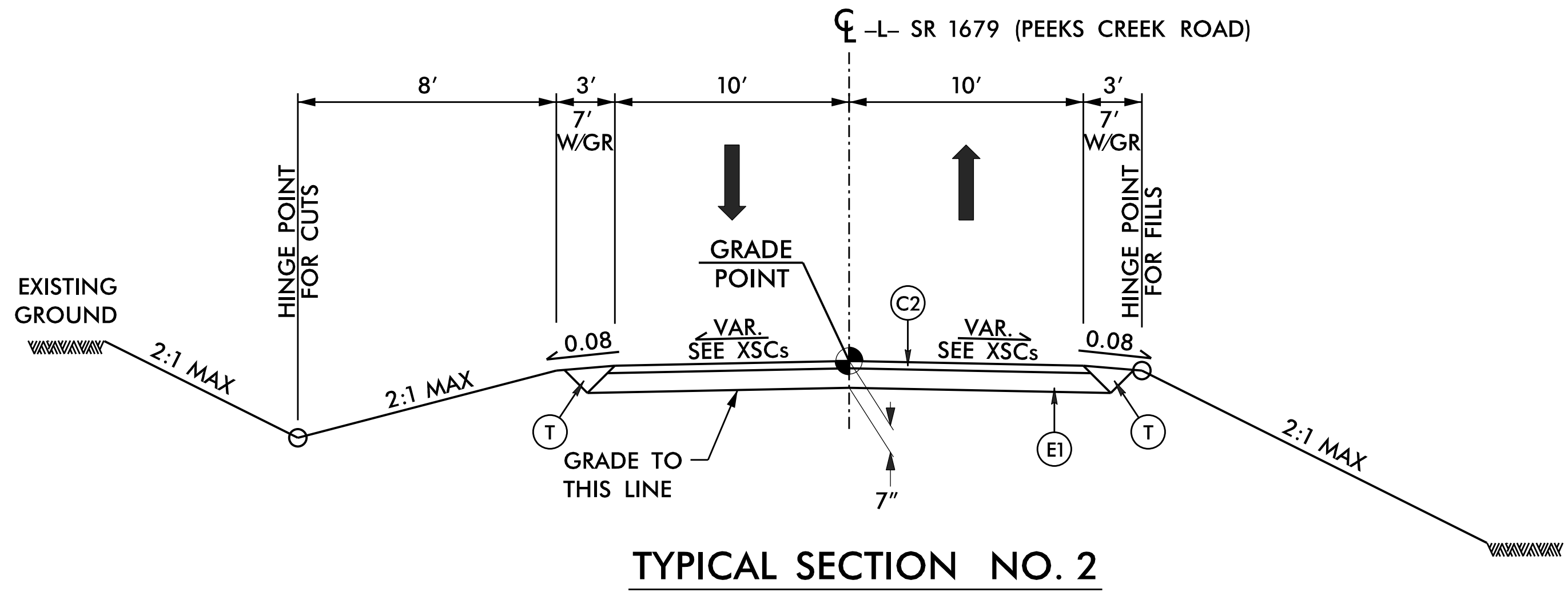

TYPICAL SECTION NO. 2

USE TYPICAL SECTION NO. 2
-L- STA. 14+85.00 TO 15+34.61
-L- STA. 16+87.30 TO 17+90.61

- NOTE:
- SEE SHEET 2B-1 FOR PAVED SHOULDER AND GUARDRAIL LOCATIONS

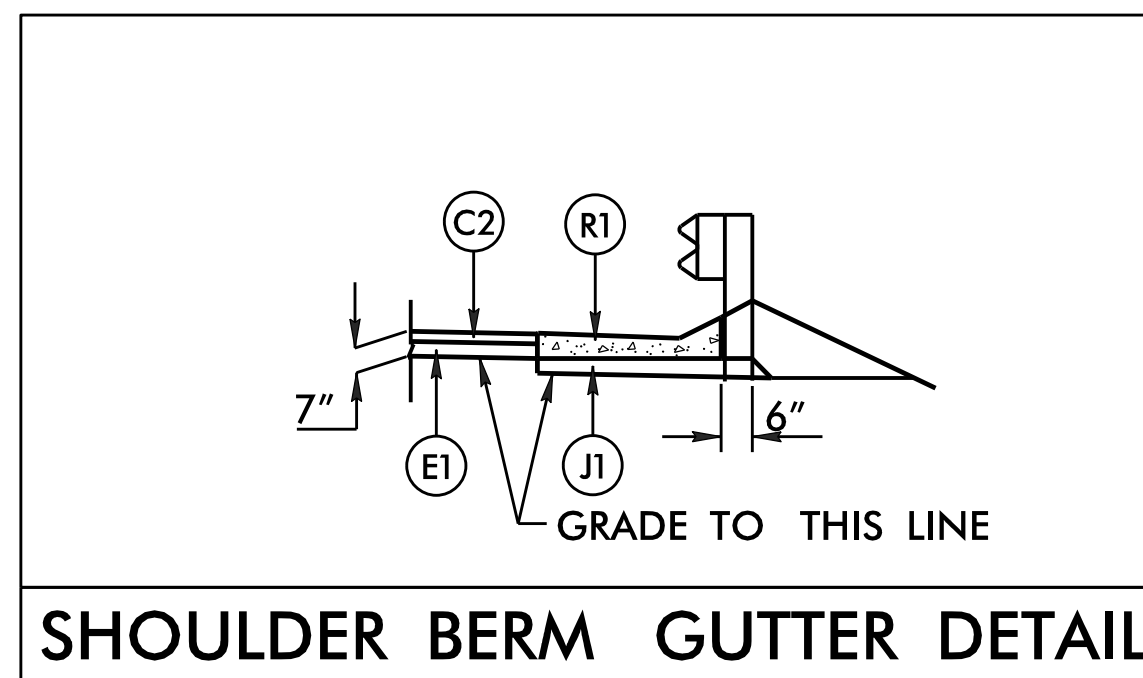

SHOULDER BERM GUTTER DETAIL

-L- STA. 17+08.42 (END APPROACH SLAB) TO -L- STA. 17+26.06 (RT)

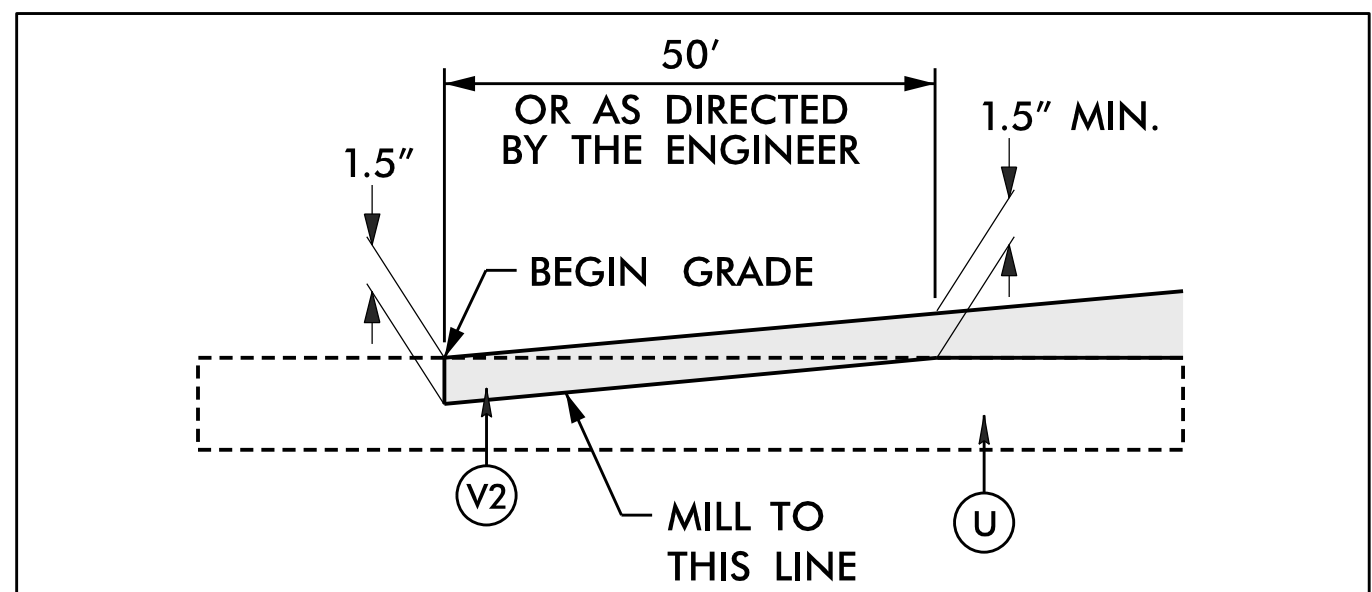

DETAIL SHOWING INCIDENTAL MILLING

-L- STA. 13+50.00 TO 14+00.00

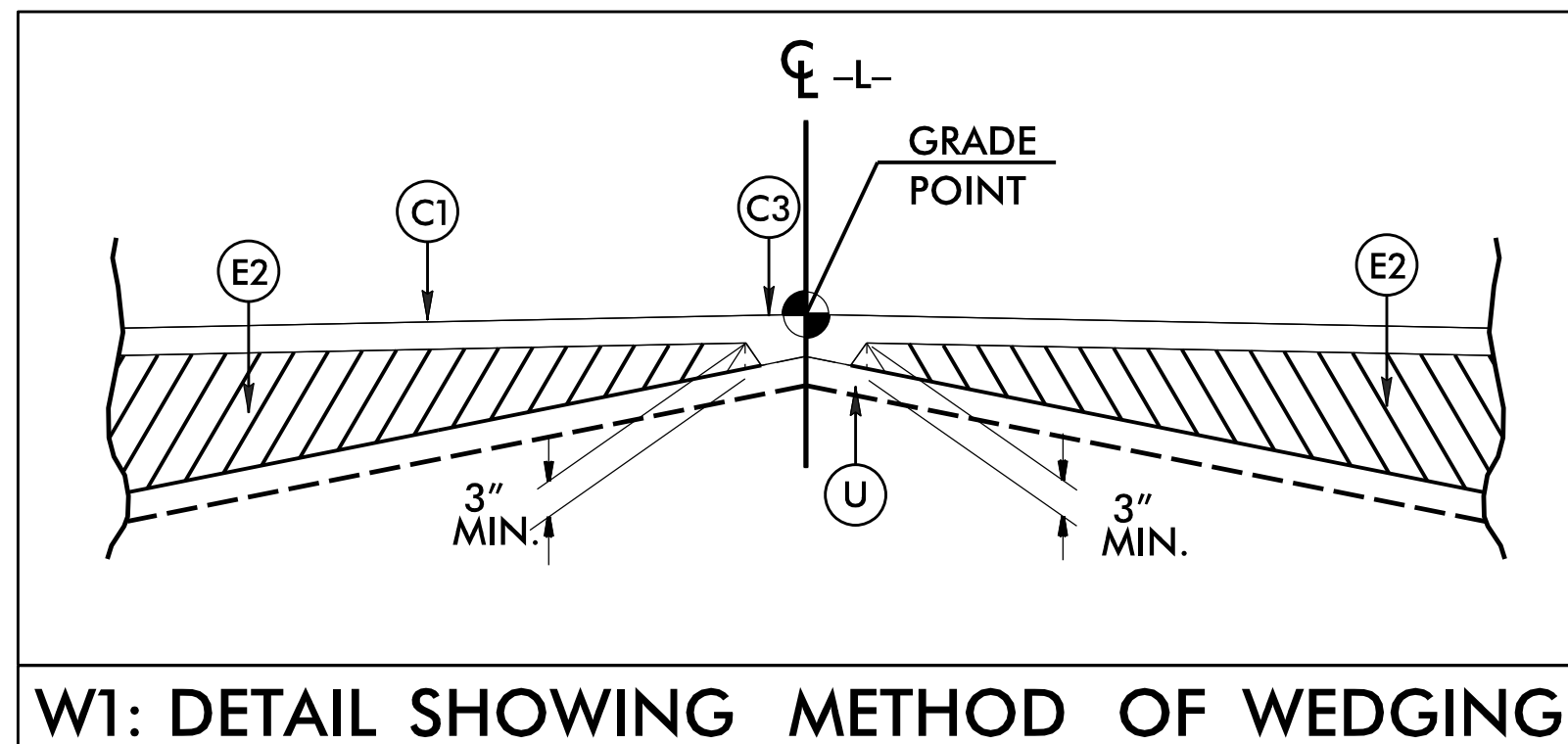

W1: DETAIL SHOWING METHOD OF WEDGING

USE THIS DETAIL IN CONJUNCTION WITH TYPICAL SECTION NO. 1

HB-0030
2A-1

NORTH CAROLINA
DEPARTMENT OF TRANSPORTATION
MACON COUNTY

ROADWAY DESIGN UNIT
ROADWAY DESIGN
ENGINEER

10/7/2025
PAVEMENT DESIGN
ENGINEER

10/7/2025
PREPARED BY
DRMP

DRMP, INC.
5808 FARMINGTON PLACE, SUITE 100
RALEIGH, NC 27609
NC LICENSE NO. F-1524 (919) 875-6115

REVISIONS

HB-0030
2A-2

NORTH CAROLINA
DEPARTMENT OF TRANSPORTATION
MACON COUNTY

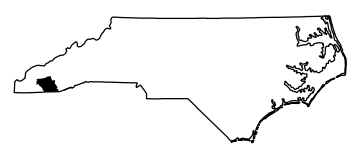

ROADWAY DESIGN UNIT
ROADWAY DESIGN ENGINEER

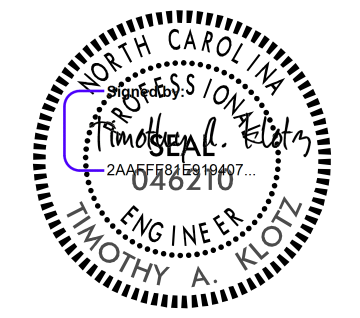

10/7/2025

PAVEMENT DESIGN ENGINEER

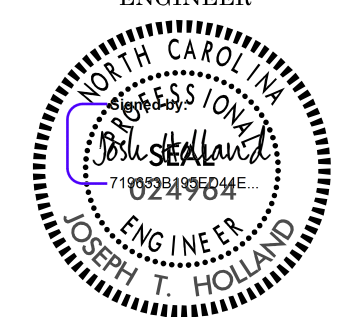

10/7/2025

PREPARED BY
DRMP

DRMP, INC.
5808 FARMGLEN PLACE, SUITE 100
RALEIGH, NC 27609
NC LICENSE NO. F-1524 (919) 875-5115

USE STRUCTURE TYPICAL SECTION
-L- STA. 15+34.61 TO 16+87.30

NOTES:

- RIGHT SHOULDER ON BRIDGE IS WIDER AND VARIES IN ORDER TO ACCOMODATE HORIZONTAL CURVE ON CORED SLAB STRUCTURE. MINIMUM SHOULDER WIDTH IS 6'-2".
- SEE STRUCTURE PLANS FOR STRUCTURE CONSTRUCTION DETAILS

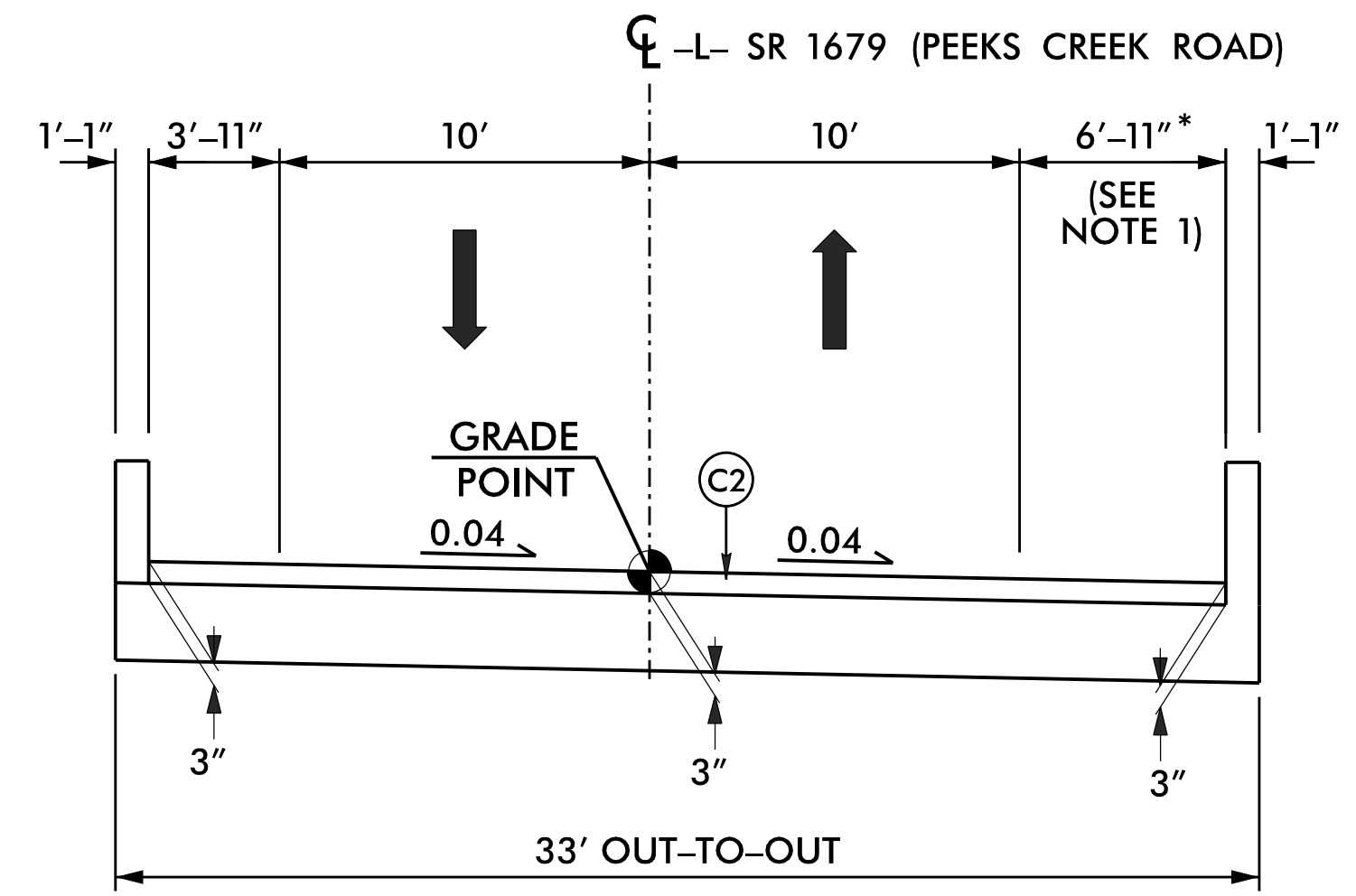

STRUCTURE TYPICAL SECTION

USE TYPICAL SECTION NO. 3
-DW1- STA. 10+10.00 TO 11+55.00

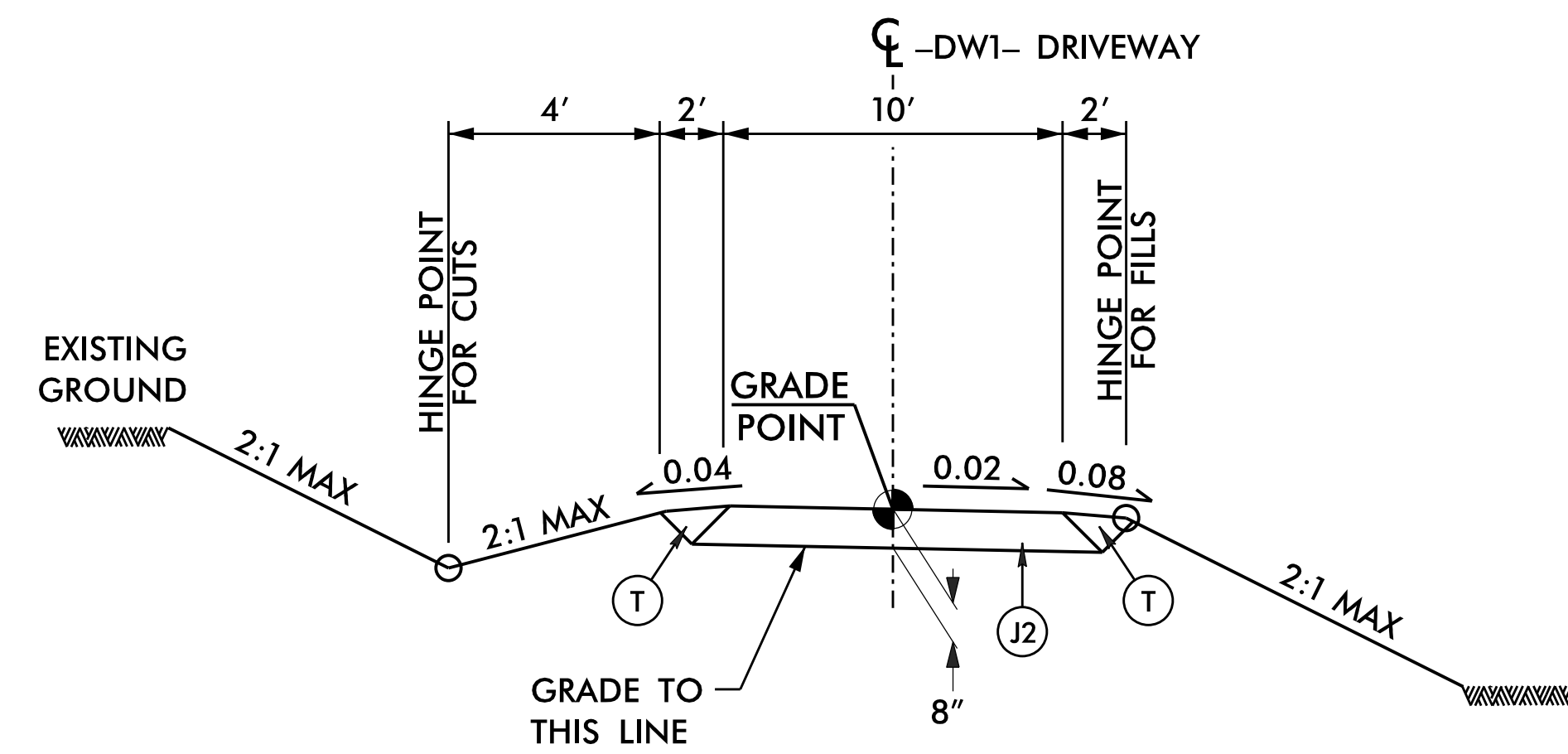

TYPICAL SECTION NO. 3

C1	1.5" S9.5B
C2	3" S9.5B
C3	VAR. DEPTH S9.5B
E1	4" B25.0C
E2	VAR. DEPTH B25.0C
J1	6" ABC
J2	8" ABC
R1	SH. BERM GUTTER
T	EARTH MATERIAL
U	EXIST. PAVEMENT
V1	1.5" MILLING
V2	INC. MILLING
W1	WEDGING DET. #1

REVISIONS

STATE OF
NORTH CAROLINA
DEPT. OF TRANSPORTATION
DIVISION OF HIGHWAYS
RALEIGH, N.C.

ENGLISH DETAIL DRAWING FOR
**TYPE III - SHOP CURVED
STRUCTURE ANCHOR UNIT**

SHEET 1 OF 1
TYPE III SC

STATE OF
NORTH CAROLINA
DEPT. OF TRANSPORTATION
DIVISION OF HIGHWAYS
RALEIGH, N.C.

ENGLISH DETAIL DRAWING FOR
**TYPE III - SHOP CURVED
STRUCTURE ANCHOR UNIT**

SHEET 1 OF 1
TYPE III SC

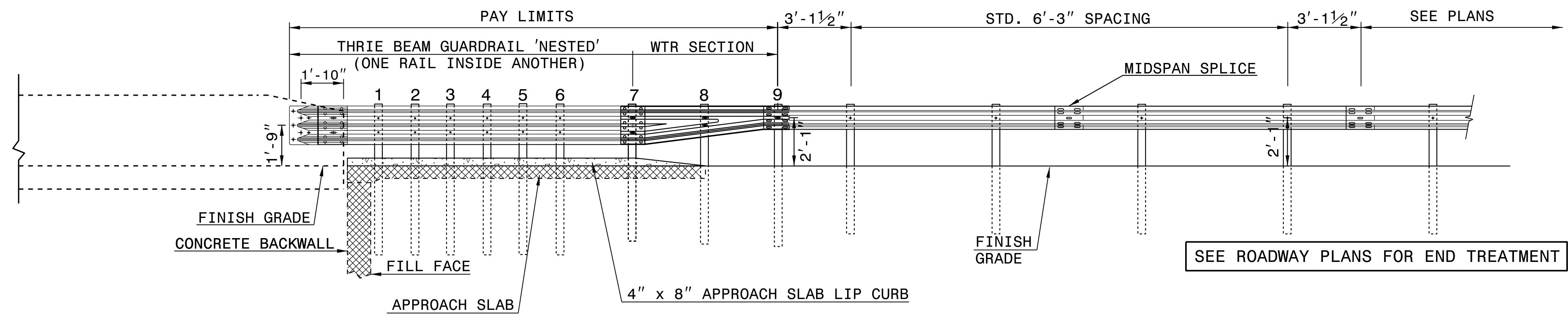

- NOTE:
- **POST NOT REQUIRED FOR SKEW ANGLES GREATER THAN 150° OR LESS THAN 30° UNLESS OTHERWISE DIRECTED BY THE ENGINEER.
 - *THE DISTANCE FROM END OF BRIDGE RAIL TO CENTER LINE OF THE FIRST POST SHOULD BE 11 1/2" IF CONCRETE BACKWALL IS NOT PRESENT.
 - SHOULDER BERM GUTTER MUST BE INSTALLED TO THE LIMITS 8" x 4" LIP CURB IS SHOWN IF ANCHOR UNIT IS NOT ADJACENT TO AN APPROACH SLAB.
 - MEASURE GUARDRAIL HEIGHT FROM THE TOP OF ADJACENT SURFACE (SHOULDER, BERM, OR GUTTER).
 - USE NO STEEL POSTS WITHIN THE GUARDRAIL ANCHOR UNIT LIMITS.
 - LAP JOINTS IN THE DIRECTION OF TRAFFIC FLOW.
 - SEE STANDARD 862.03 SHEET 4 FOR POST SECTIONS 1 THRU 9.

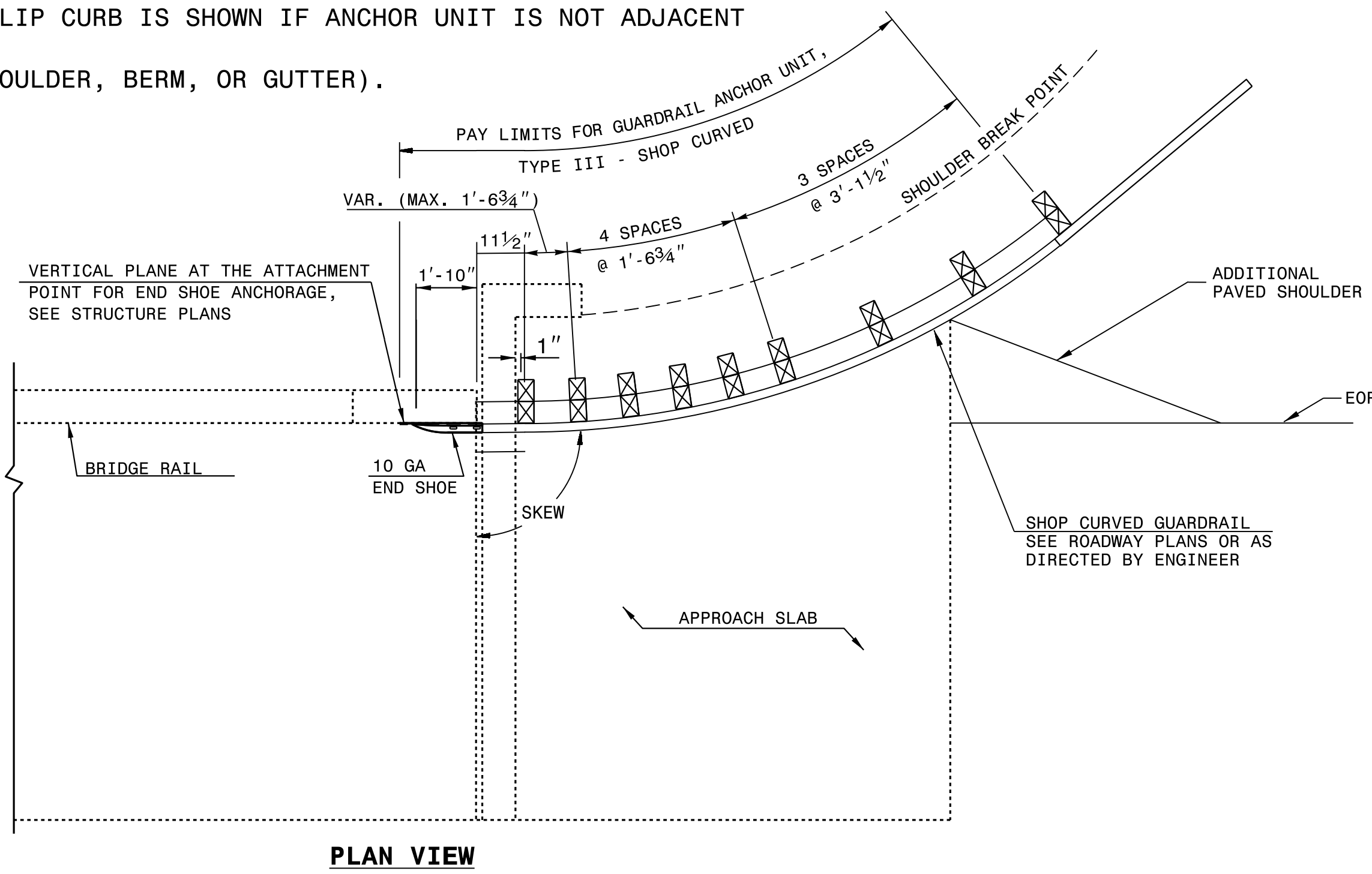

**GUARDRAIL ANCHOR UNIT, TYPE III - SHOP CURVED
FOR ATTACHMENT TO RAIL ON BRIDGE**

01-FEB-2018 09:49 S:\Contracts\Special Details\howerton\Guardrail\31 inch Guardrail\type_iii_sc.dgn Jhowerton AT CSD-292595

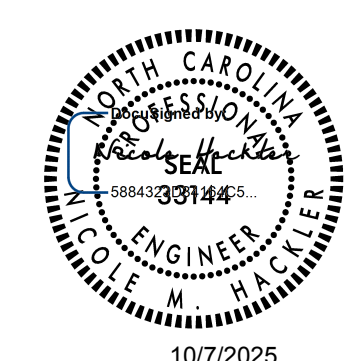

DOCUMENT NOT CONSIDERED FINAL
UNLESS ALL SIGNATURES COMPLETED

**CONTRACT STANDARDS
AND DEVELOPMENT UNIT**
Office 919-707-6950 FAX 919-250-4119

SEE PLATE FOR TITLE

ORIGINAL BY: E.E.Ward DATE: 4-4-02
 MODIFIED BY: T.S.Spell DATE: 2-01-18
 CHECKED BY: DATE:
 FILE SPEC.: Jhowerton\guardrail\31inguardrail\typeiiiisc.dgn

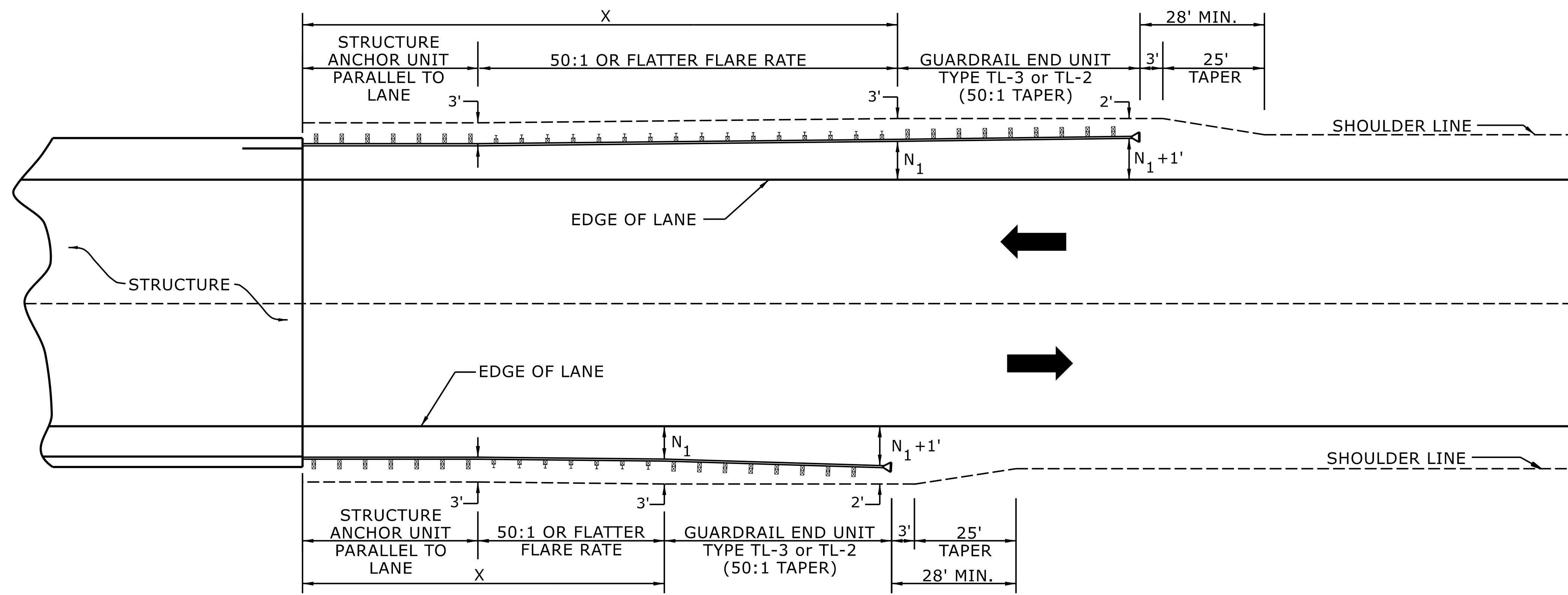

USE FLARE RATE AS THE CONTROL IF THE " N_1 " DISTANCE IS NOT OBTAINED.
 (" N_1 " IS BASED ON SHOULDER WIDTHS IN THE ROADWAY DESIGN MANUAL)
 SEE STD. 862.03 FOR STRUCTURE ANCHOR UNITS
 FOR POSTED SPEEDS \geq 45MPH USE GREU TYPE TL-3
 FOR POSTED SPEEDS $<$ 45MPH USE GREU TYPE TL-2
 GUARDRAIL LENGTH OF NEED (X) IS CALCULATED BASED ON THE AASHTO ROADSIDE DESIGN GUIDE.

LENGTHS AND OFFSETS FOR PROPOSED GUARDRAIL AT TWO LANE - TWO WAY LOCATIONS

STATE OF
 NORTH CAROLINA
 DEPT. OF TRANSPORTATION
 DIVISION OF HIGHWAYS
 RALEIGH, N.C.

ROADWAY DETAIL DRAWING FOR
GUARDRAIL PLACEMENT

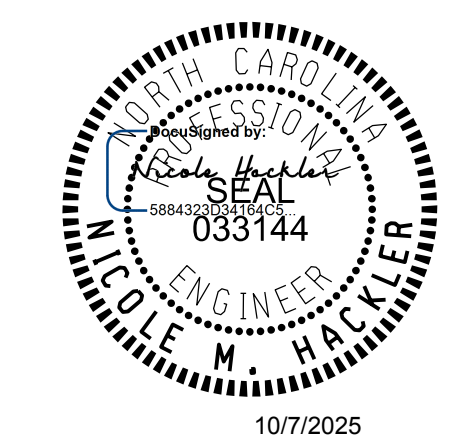

SHEET 4 OF 15
862D01

DOCUMENT NOT CONSIDERED FINAL
 UNLESS ALL SIGNATURES COMPLETED

**CONTRACTS STANDARDS
 AND DEVELOPMENT UNIT**
 Office 919-707-6950 FAX 919-250-4119

SEE TITLE BLOCK

ORIGINAL BY: S.CALHOUN DATE: 7-25-2024
 MODIFIED BY: _____ DATE: _____
 CHECKED BY: _____ DATE: _____
 FILE SPEC.: _____

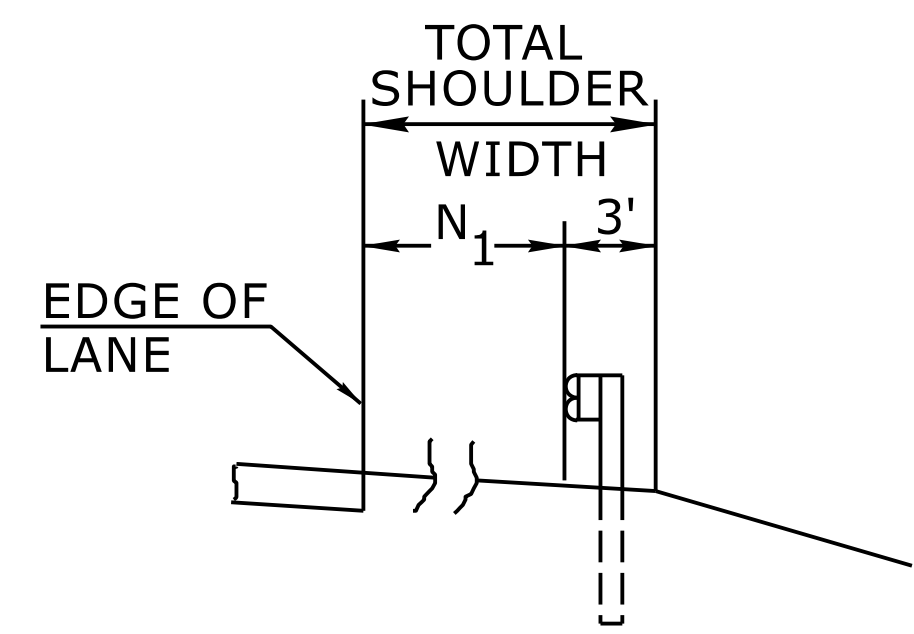

FILL SECTION

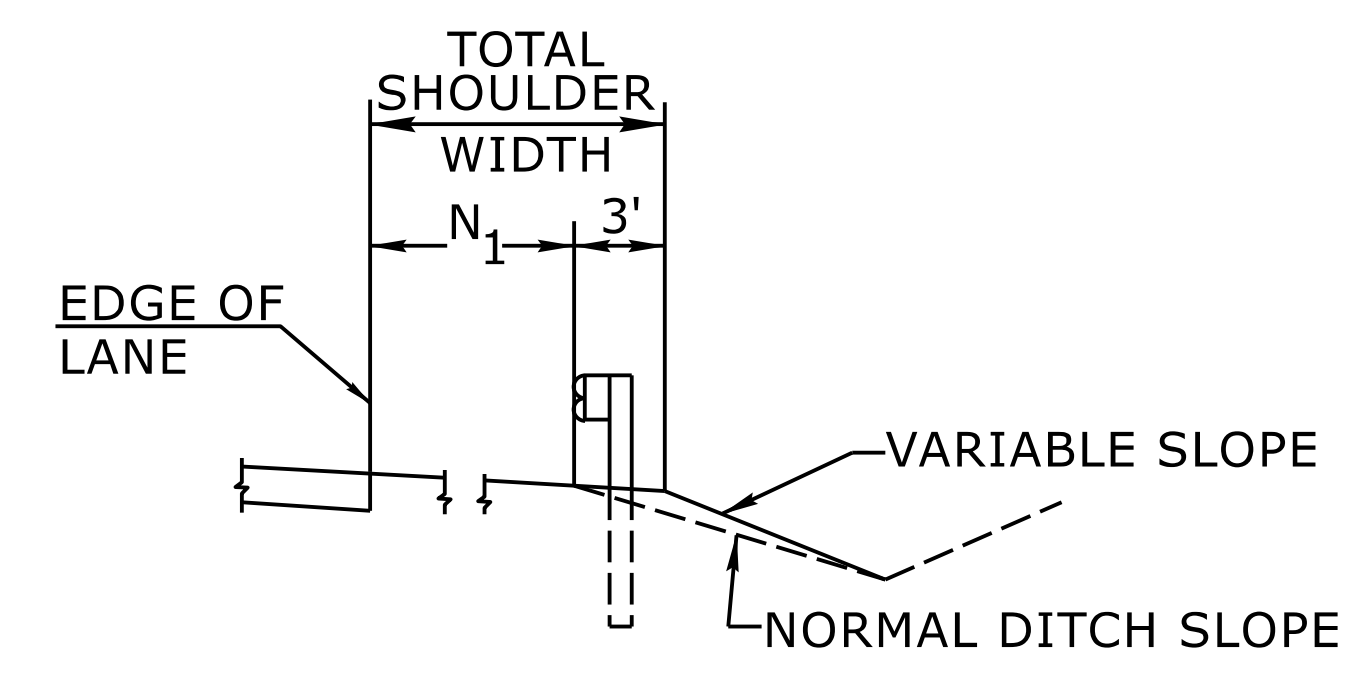

CUT SECTION

"N₁" = DISTANCE FROM EDGE OF LANE TO FACE OF GUARDRAIL WHERE GUARDRAIL IS PARALLEL TO LANE.

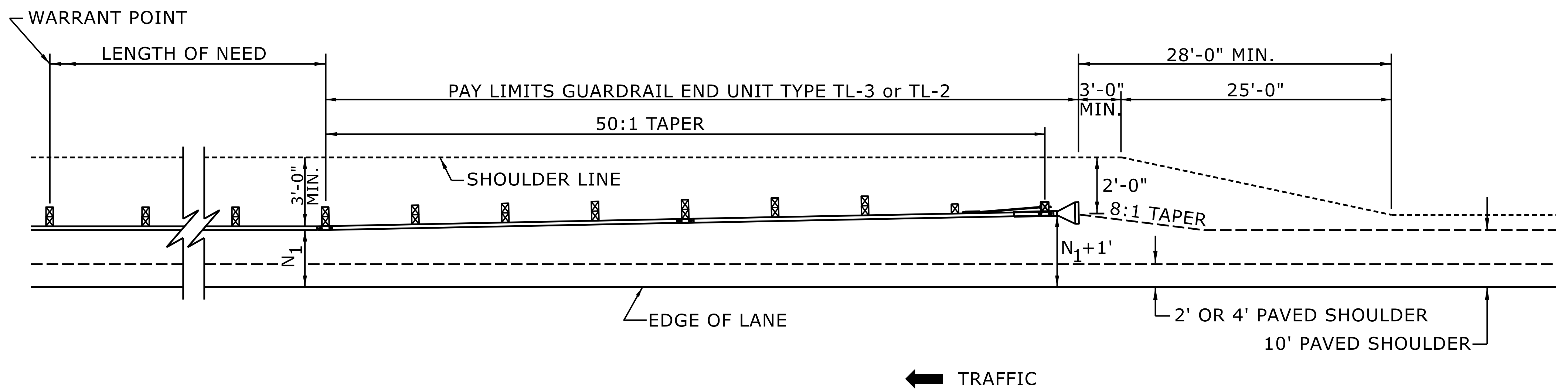

FOR POSTED SPEEDS ≥ 45mph USE GREU TYPE TL-3
FOR POSTED SPEEDS < 45mph USE GREU TYPE TL-2

DETAIL OF BEGINNING OF GUARDRAIL IN CUT OR FILL SECTION

STATE OF
NORTH CAROLINA
DEPT. OF TRANSPORTATION
DIVISION OF HIGHWAYS
RALEIGH, N.C.

ROADWAY DETAIL DRAWING FOR
GUARDRAIL PLACEMENT

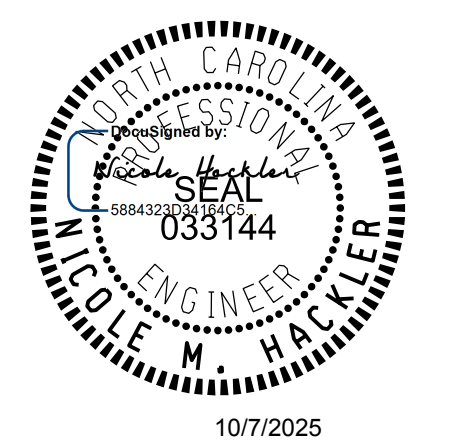

SHEET 6 OF 15
862D01

DOCUMENT NOT CONSIDERED FINAL
UNLESS ALL SIGNATURES COMPLETED



**CONTRACTS STANDARDS
AND DEVELOPMENT UNIT**
Office 919-707-6950 FAX 919-250-4119

SEE TITLE BLOCK

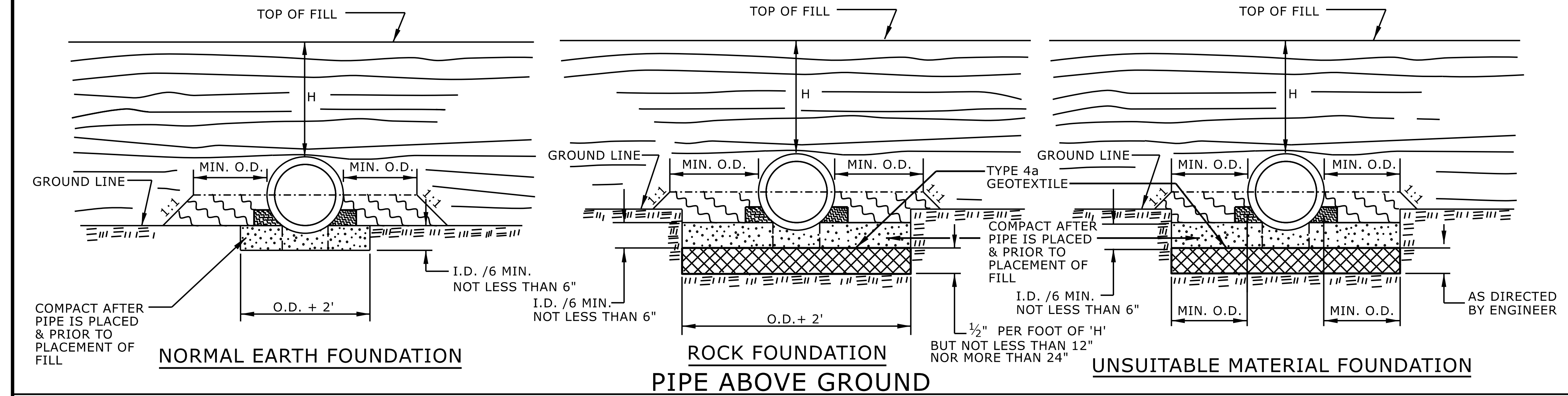
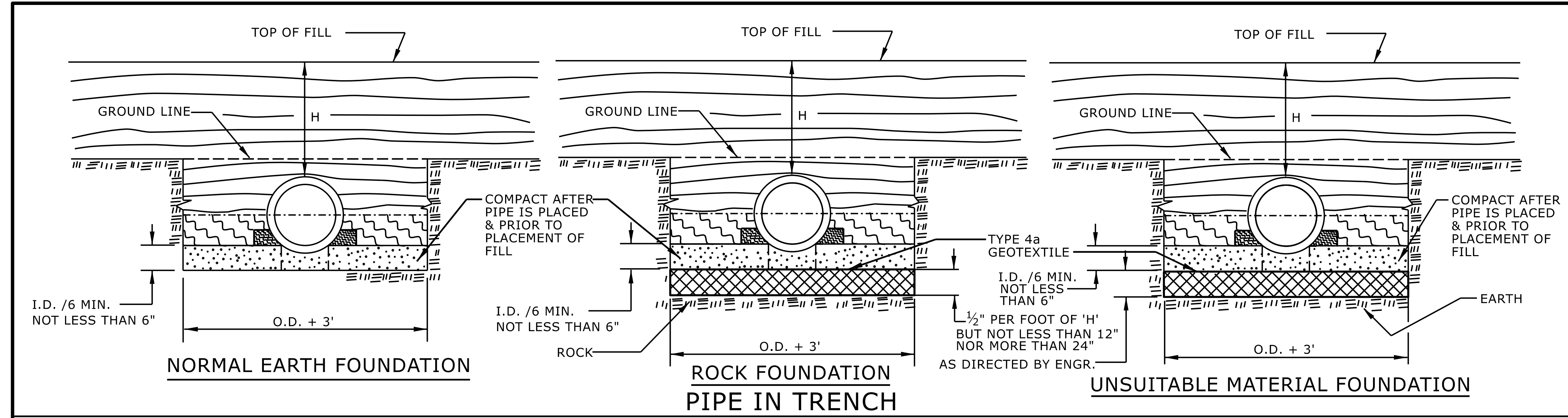
ORIGINAL BY: S.CALHOUN	DATE: 7-25-2024
MODIFIED BY:	DATE:
CHECKED BY:	DATE:
FILE SPEC.:	



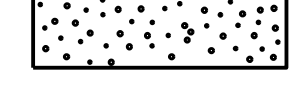

GENERAL NOTES:
 I.D. = THE MAXIMUM HORIZONTAL INSIDE DIAMETER DIMENSION.
 O.D. = THE MAXIMUM HORIZONTAL OUTSIDE DIAMETER DIMENSION.
 H = THE FILL HEIGHT MEASURED VERTICALLY AT ANY POINT ALONG THE PIPE FROM THE TOP OF THE PIPE TO THE TOP OF THE EMBANKMENT AT THAT POINT.

-  APPROVED SUITABLE LOCAL MATERIAL.
-  TAKE CARE TO FULLY COMPACT HAUNCH ZONE OF PIPE BACKFILL.
-  LOOSELY PLACED SELECT MATERIAL CLASS III OR CLASS II, TYPE 1 FOR PIPE BEDDING. LEAVE SECTION DIRECTLY BENEATH PIPE UNCOMPACTED AS PIPE SEATING AND BACKFILL WILL ACCOMPLISH COMPACTION.

DO NOT OPERATE HEAVY EQUIPMENT OVER ANY PIPE CULVERT UNTIL THE PIPE CULVERT HAS BEEN PROPERLY BACKFILLED AND COVERED WITH AT LEAST 3 FEET OF APPROVED MATERIAL.

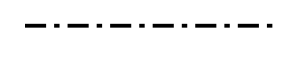
REFER TO NCDOT PIPE MATERIAL SELECTION GUIDE AND STANDARD SPECIFICATIONS FOR ALLOWABLE PIPE FILL HEIGHTS AND PIPE SPECIFICATIONS.

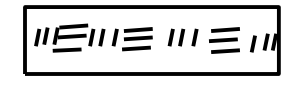
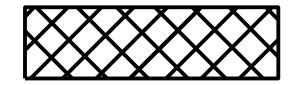
-  SPRINGLINE OF PIPE
-  SELECT BACKFILL MATERIAL CLASS III OR CLASS II, BELOW SPRINGLINE.
-  UNDISTURBED EARTH MATERIAL
-  SELECT MATERIAL CLASS V OR VI FOR FOUNDATION CONDITIONING. ENCAPSULATE WITH TYPE IV GEOTEXTILE AS DIRECTED BY THE ENGINEER.

STATE OF
 NORTH CAROLINA
 DEPT. OF TRANSPORTATION
 DIVISION OF HIGHWAYS
 RALEIGH, N.C.

ROADWAY DETAIL DRAWING FOR
METHOD OF PIPE INSTALLATION
 RIGID PIPE

SHEET 2 OF 2
300.01

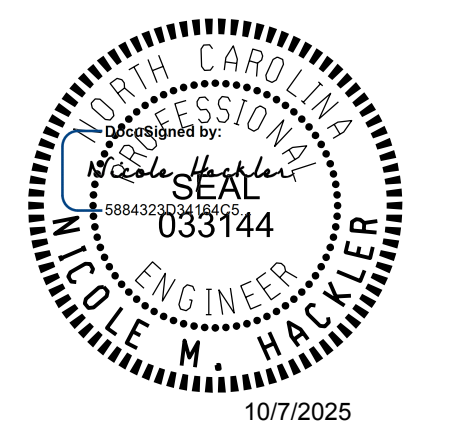

DOCUMENT NOT CONSIDERED FINAL
 UNLESS ALL SIGNATURES COMPLETED

**CONTRACTS STANDARDS
 AND DEVELOPMENT UNIT**
 Office 919-707-6950 FAX 919-250-4119

SEE TITLE BLOCK

ORIGINAL BY: S.CALHOUN DATE: 7-25-2024
 MODIFIED BY: DATE: _____
 CHECKED BY: DATE: _____
 FILE SPEC.: _____

RAL/ETHERIDGE

COMPUTED BY: JAKE ETHERIDGE DATE: 06/27/2024
CHECKED BY: RYAN MITCHELL DATE: 06/27/2024

PROJECT NO. HB-0030 SHEET NO. 3D-1

NORTH CAROLINA DEPARTMENT OF TRANSPORTATION
DIVISION OF HIGHWAYS

Note: Invert Elevations indicated are for Bid Purposes only and shall not be used for project construction stakeout.
See "Standard Specifications For Roads and Structures, Section 300-5".

LIST OF PIPES, ENDWALLS, ETC. (FOR PIPES 48 INCHES & UNDER)

Main data table with columns for Line & Station, Offset, Structure Number, Pipe Type (Drainage, C.S., R.C. Class III, IV, V), Quantities for Drainage Structures, Frame/Grates, and Pipe Removal. Includes a grid for recording quantities and elevations.

ABBREVIATIONS table listing materials like C.A.A. CORRUGATED ALUMINIUM ALLOY, C.B. CATCH BASIN, C.S. CORRUGATED STEEL, D.I. DROP INLET, G.D.I. GRATED DROP INLET, H.D.P.E. HIGH DENSITY POLYETHYLENE, J.B. JUNCTION BOX, M.H. MANHOLE, N.S. NARROW SLOT, P.V.C. POLYVINYL CHLORIDE, R.C. REINFORCED CONCRETE, T.B.D.I. TRAFFIC BEARING DROP INLET, T.B.J.B. TRAFFIC BEARING JUNCTION BOX, W.S. WIDE SLOT.

SHEET TOTALS and PROJECT TOTALS summary rows at the bottom of the table.

COMPUTED BY: DM Mullen, PE DATE: 4/3/2025
 CHECKED BY: S Yang, PhD, PE DATE: 4/3/2025

(9-17-24)

PROJECT NO.	SHEET NO.
HB-0030	3G-1

**STATE OF NORTH CAROLINA
 DIVISION OF HIGHWAYS**

SUMMARY OF SUBSURFACE DRAINAGE

SUMMARY OF AGGREGATE SUBGRADE/STABILIZATION

LINE	Station	Station	Location LT/RT/CL	Drain Type* UD/BD/SD	LF
	CONTINGENCY			SD	200
				TOTAL LF:	200

*UD = Underdrain
 *BD = Blind Drain
 *SD = Subsurface Drain

LINE	Station	Station	Aggregate Type* ASU(1/2)/ AST	Aggregate Thickness INCHES [8" for ASU(2)]	Shallow Undercut CY	Class IV Subgrade Stabilization TONS	Geotextile for Subgrade Stabilization SY	Stabilizer Aggregate TONS	Class IV Aggregate Stabilization TONS
	CONTINGENCY		ASU		100	200	300		
			TOTAL CY/TONS/SY:		100	200**	300**	0	0

*ASU(1/2) = Aggregate Subgrade (Type 1 or 2)
 *AST = Aggregate Stabilization
 **Total tons of "Class IV Subgrade Stabilization" and total square yards of "Geotextile for Subgrade Stabilization" are only the estimated quantities for ASU(1/2)/AST and may only represent a portion of the subgrade stabilization and geotextile quantities shown in the Item Sheets of the Proposal.

HB-0030
4

NORTH CAROLINA
DEPARTMENT OF TRANSPORTATION
MCCON COUNTY

ROADWAY DESIGN UNIT
ROADWAY DESIGN ENGINEER

10/7/2025

HYDRAULICS ENGINEER

10/7/2025

PREPARED BY
DRMP

DRMP, INC.
5808 FARMINGTON PLACE, SUITE 100
RALEIGH, NC 27608
NC LICENSE NO. F-1524 (919) 873-8115



CUR DATA -L- Plc 11+20.89 $\Delta c = 07^{\circ}53'14.2''$ (RT) D = 04'57'53.9" Lc = 158.86 Tc = 79.55 R = 1,154 SE = EXIST.	CUR DATA -L- Plc 13+58.90 $\Delta c = 04^{\circ}25'53.5''$ (RT) D = 03'46'54.8" Lc = 117.18 Tc = 60.59 R = 1,515 SE = EXIST.	CUR DATA -L- Plc 14+94.81 $\Delta c = 19^{\circ}38'35.5''$ (RT) D = 16'22'12.8" Lc = 119.99 Tc = 60.59 R = 350 SE = 0.040 R.O. = 60' DS = 30 MPH	CUR DATA -L- Plc 17+31.98 $\Delta c = 24^{\circ}08'25.0''$ (RT) D = 22'38'47.6" Lc = 106.60 Tc = 54.10 R = 253 SE = 0.040 R.O. = 60' DS = 30 MPH	CUR DATA -L- Plc 19+24.54 $\Delta c = 38^{\circ}33'20.0''$ (LT) D = 27'01'34.7" Lc = 142.66 Tc = 74.15 R = 212 SE = EXIST.	CUR DATA -L- Plc 20+35.60 $\Delta c = 06^{\circ}25'00.0''$ (LT) D = 07'32'55.9" Lc = 85.00 Tc = 42.55 R = 759 SE = EXIST.	CUR DATA -L- Plc 22+06.98 $\Delta c = 14^{\circ}31'25.8''$ (LT) D = 09'10'02.4" Lc = 158.43 Tc = 79.64 R = 625 SE = EXIST.
--	--	--	--	--	---	--

CUR DATA -DW1- Plc 10+38.86 $\Delta c = 74^{\circ}35'54.9''$ (LT) D = 143'14'22.0" Lc = 52.08 Tc = 30.47 R = 40 SE = NC	CUR DATA -DW1- Plc 11+34.28 $\Delta c = 62^{\circ}22'30.7''$ (RT) D = 143'14'22.0" Lc = 43.55 Tc = 24.21 R = 40 SE = NC
---	---

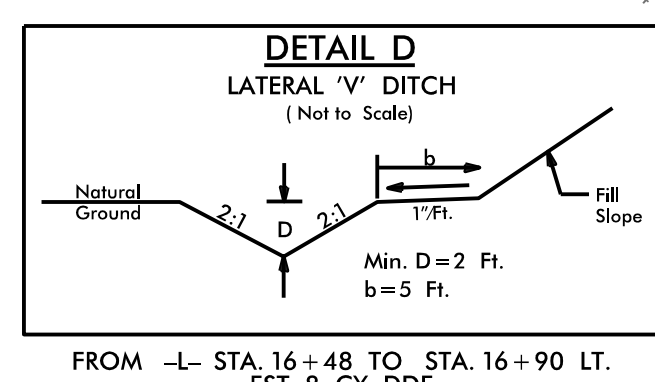
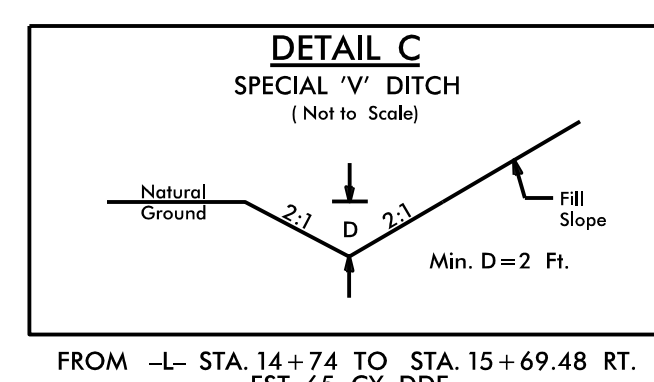
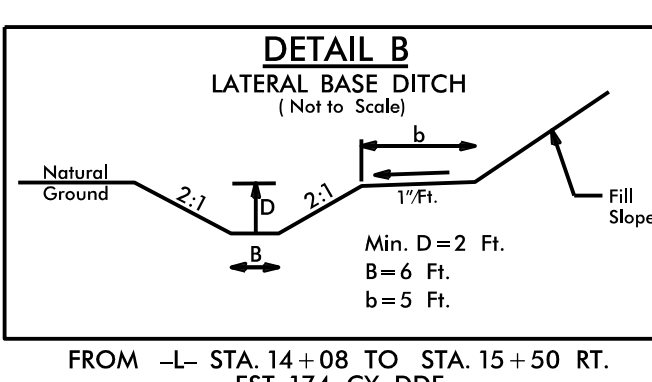
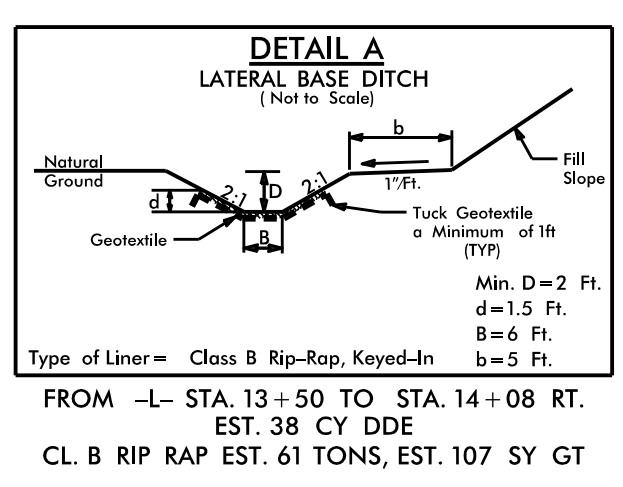
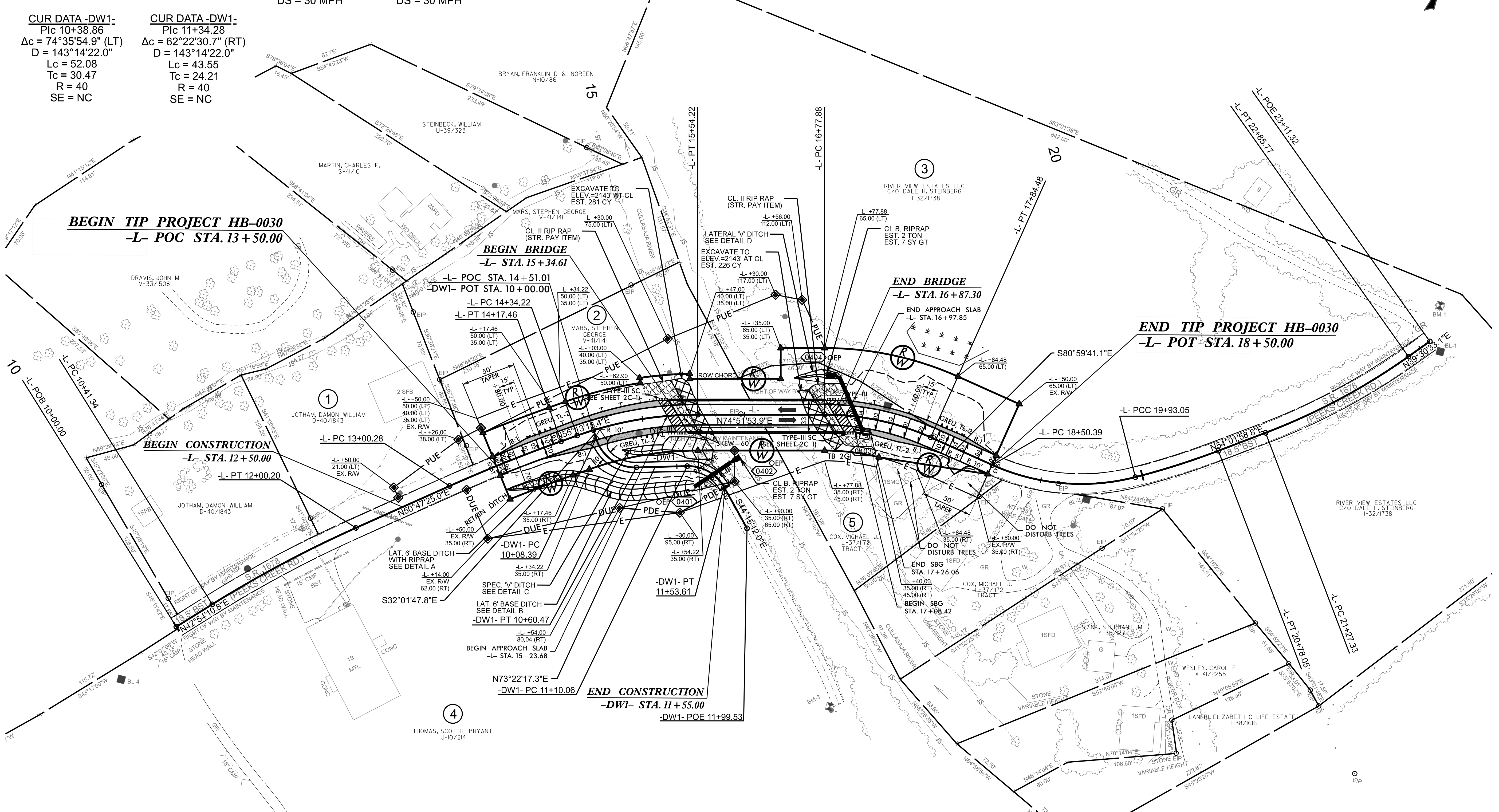

FOR -L- PROFILE SEE SHEET 5
FOR -DW1- PROFILE SEE SHEET 5
FOR PAVED SHOULDER AND
GUARDRAIL DETAILS SEE SHEET 2B-1
FOR STRUCTURE PLANS SEE
SHEETS S-1 THROUGH S-27

REVISIONS

HB-0030
5

NORTH CAROLINA
DEPARTMENT OF TRANSPORTATION
MACON COUNTY

ROADWAY DESIGN UNIT
ROADWAY DESIGN
ENGINEER

10/7/2025

HYDRAULICS
ENGINEER

10/7/2025

PREPARED BY
DRMP

DRMP, INC.
5808 FARMINGTON PLACE, SUITE 100
RALEIGH, NC 27609
NC LICENSE NO. E-1524 (P) 87251115

DOCUMENT NOT CONSIDERED FINAL
UNLESS ALL SIGNATURES COMPLETE

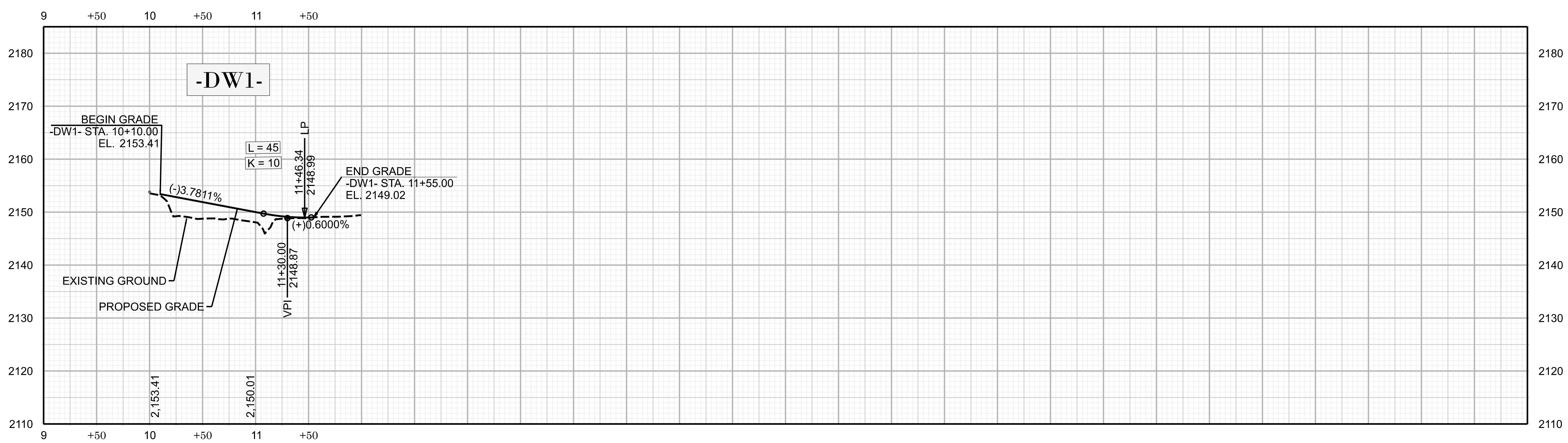
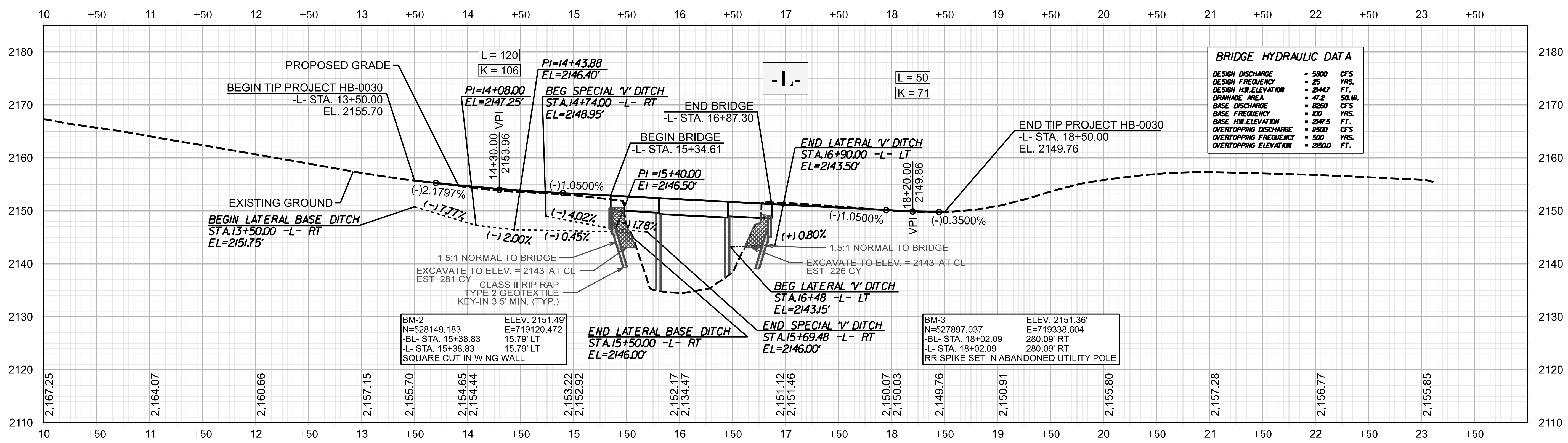

FOR -DW1- PLAN VIEW SEE SHEET 4

STATE OF NORTH CAROLINA DIVISION OF HIGHWAYS

STATE N.C.	STATE PROJECT REFERENCE NO. HB-0030	SHEET NO. RW01	TOTAL SHEETS 5
---------------	--	-------------------	-------------------

SURVEY CONTROL, EXISTING CENTERLINES,
RIGHT OF WAY, EASEMENTS AND PROPERTY TIES

MACON COUNTY

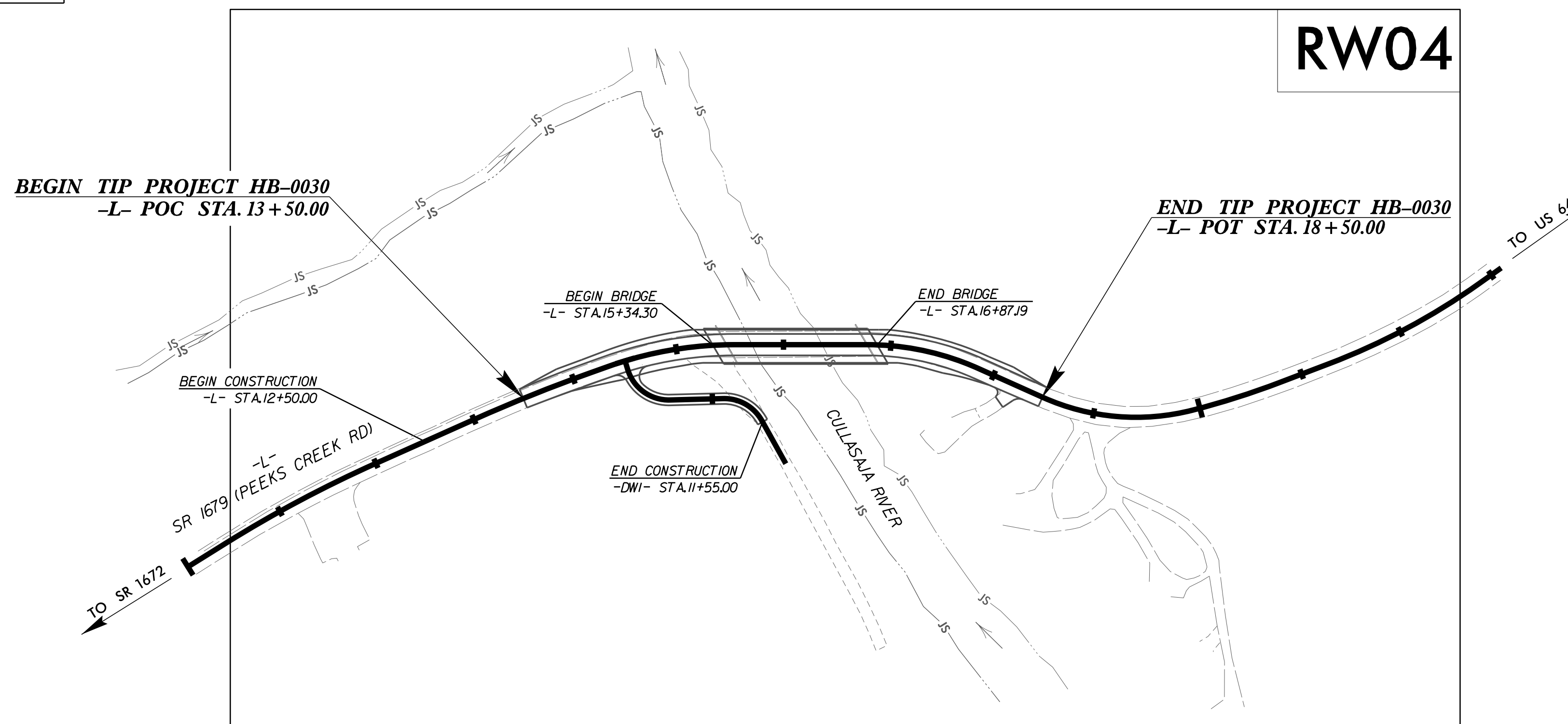
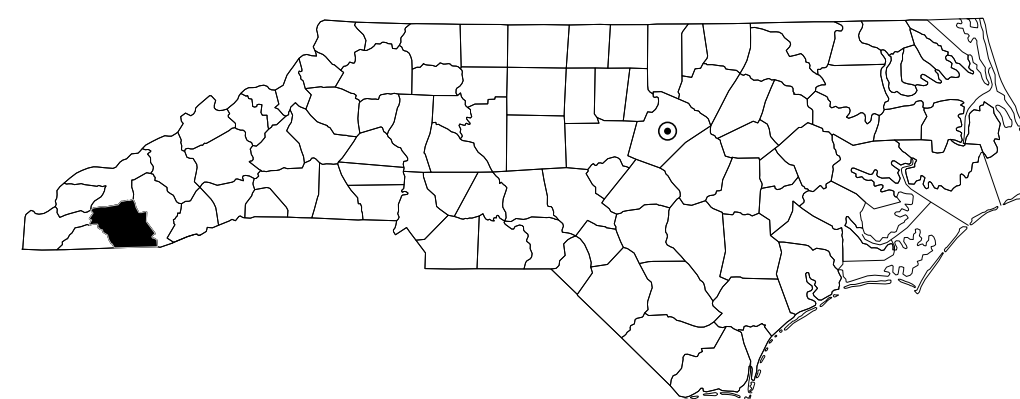
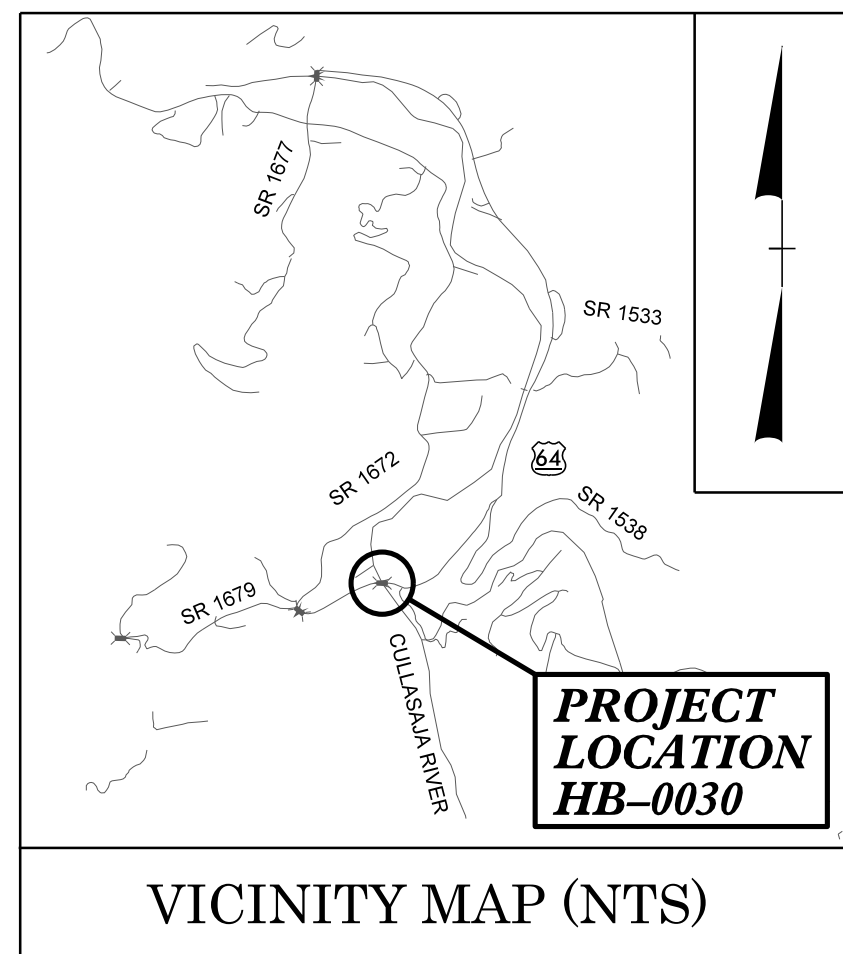

DOCUMENT NOT CONSIDERED FINAL
UNLESS ALL SIGNATURES COMPLETED

GRAPHIC SCALES



DATUM DESCRIPTION

THE LOCALIZED COORDINATE SYSTEM DEVELOPED FOR THIS PROJECT IS BASED ON THE STATE PLANE COORDINATES ESTABLISHED BY NCDOT FOR MONUMENT HB-0030-G102 WITH NAD83/NA2011 STATE PLANE GRID COORDINATES OF NORTHING: 527878.7180' EASTING: 718755.1360' ELEVATION: 2164.43'

THE AVERAGE COMBINED GRID FACTOR USED ON THIS PROJECT (GROUND TO GRID) IS: 0.999776301

ALL LINEAR DIMENSIONS ARE LOCALIZED HORIZONTAL DISTANCES

VERTICAL DATUM USED IS NAVD 88

Prepared in the Office of:

LOCATION AND SURVEYS
DIVISION 14
122 BONNIE LANE
SYLVA, NC 28779

2024 STANDARD SPECIFICATIONS

RIGHT OF WAY DATE:
OCTOBER 11, 2024

LETTING DATE:
DECEMBER 9, 2025

PROFESSIONAL LAND
SURVEYOR



DocuSigned by:
Brian Barwatt
SIGNATURE: DATE: 10/02/2025

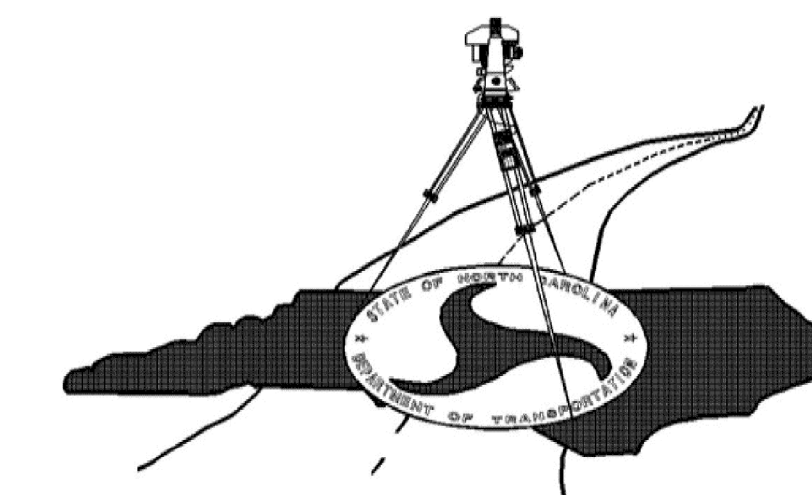

TIP PROJECT: HB-0030

09/08/09

SURVEY CONTROL SHEET

W/EXISTING CENTERLINE ALIGNMENTS PRIOR TO CONSTRUCTION

HB-0030 BASELINE CONTROL				
POINT	DESC	NORTH	EAST	ELEVATION
1	BL1	528396.998	719823.041	2154.96
101	GPS101	528106.019	719089.444	2152.17
102	GPS102	527878.718	718755.136	2164.43
2	BL2	528157.994	719527.448	2153.21
3	BL3	528194.857	719316.371	2149.86
4	BL4	527742.309	718664.46	2169.73

BENCHMARK	NORTHING	EASTING	ELEVATION	DESCRIPTION
BM1	528430.162	719811.277	2154.08	RR SPIKE SET IN BASE OF 12" OAK
BM2	528149.183	719120.472	2151.49	SQUARE CUT IN WING WALL
BM3	527897.037	719338.604	2151.36	RR SPIKE SET IN ABANDONED UTILITY POLE

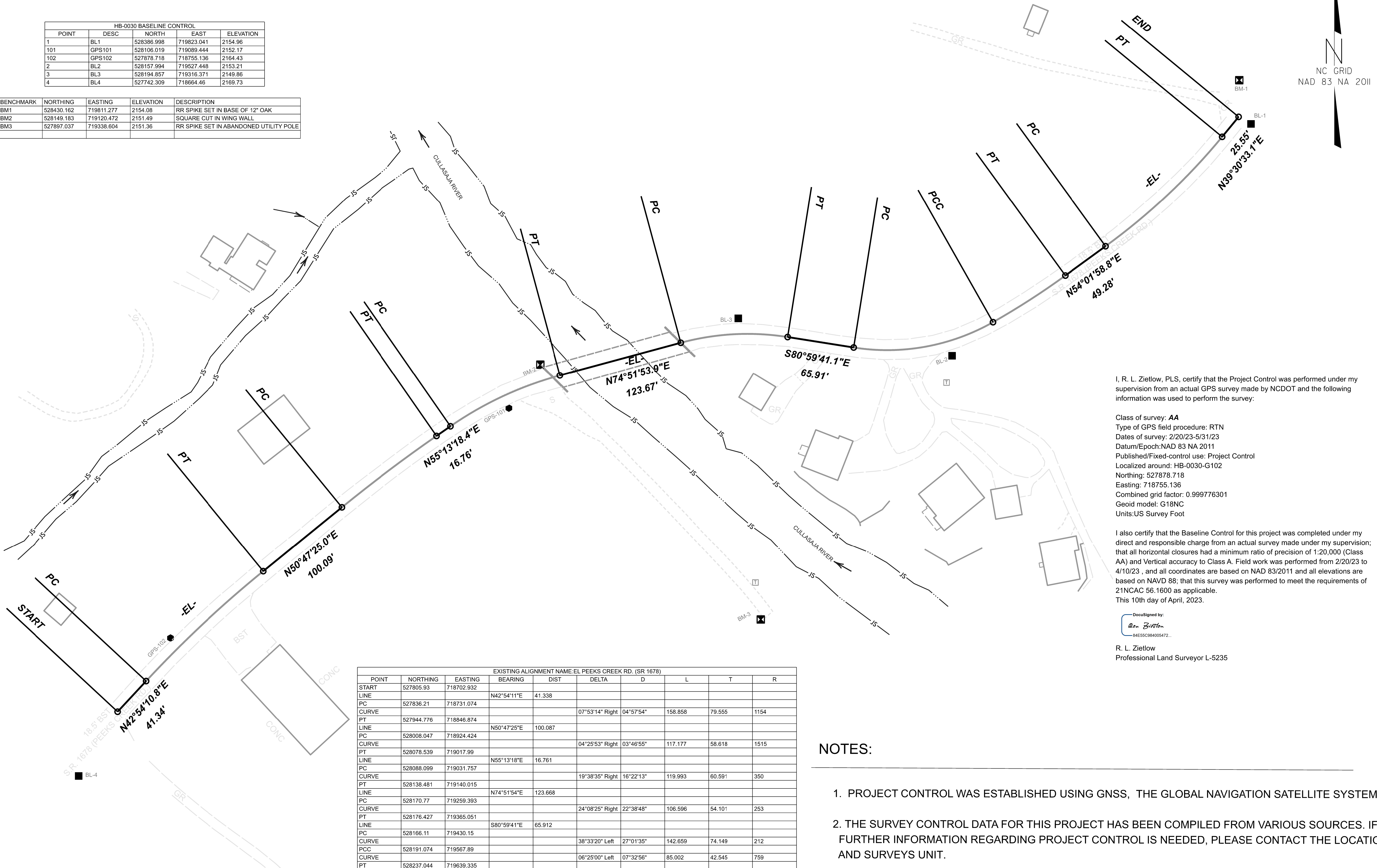

I, R. L. Zietlow, PLS, certify that the Project Control was performed under my supervision from an actual GPS survey made by NCDOT and the following information was used to perform the survey:

Class of survey: AA
 Type of GPS field procedure: RTN
 Dates of survey: 2/20/23-5/31/23
 Datum/Epoch: NAD 83 NA 2011
 Published/Fixed-control use: Project Control
 Localized around: HB-0030-G102
 Northing: 527878.718
 Easting: 718755.136
 Combined grid factor: 0.999776301
 Geoid model: G18NC
 Units: US Survey Foot

I also certify that the Baseline Control for this project was completed under my direct and responsible charge from an actual survey made under my supervision; that all horizontal closures had a minimum ratio of precision of 1:20,000 (Class AA) and Vertical accuracy to Class A. Field work was performed from 2/20/23 to 4/10/23, and all coordinates are based on NAD 83/2011 and all elevations are based on NAVD 88; that this survey was performed to meet the requirements of 21NCAC 56.1600 as applicable. This 10th day of April, 2023.

DocuSigned by:

 84E55C984005472...

R. L. Zietlow
 Professional Land Surveyor L-5235

EXISTING ALIGNMENT NAME EL PEEKS CREEK RD. (SR 1678)									
POINT	NORTHING	EASTING	BEARING	DIST	DELTA	D	L	T	R
START	527805.93	718702.932							
LINE			N42°54'11"E	41.338					
PC	527836.21	718731.074							
CURVE					07°53'14" Right	04°57'54"	158.858	79.555	1154
PT	527944.776	718846.874							
LINE			N50°47'25"E	100.087					
PC	528008.047	718924.424							
CURVE					04°25'53" Right	03°46'55"	117.177	58.618	1515
PT	528078.539	719017.99							
LINE			N55°13'18"E	16.761					
PC	528088.099	719031.757							
CURVE					19°38'35" Right	16°22'13"	119.993	60.591	350
PT	528138.481	719140.015							
LINE			N74°51'54"E	123.668					
PC	528170.77	719259.393							
CURVE					24°08'25" Right	22°38'48"	106.596	54.101	253
PT	528176.427	719365.051							
LINE			S80°59'41"E	65.912					
PC	528166.11	719430.15							
CURVE					38°33'20" Left	27°01'35"	142.659	74.149	212
PCC	528191.074	719567.89							
CURVE					06°25'00" Left	07°32'56"	85.002	42.545	759
PT	528237.044	719639.335							
LINE			N54°01'59"E	49.282					
PC	528265.989	719679.222							
CURVE					14°31'26" Left	09°10'02"	158.43	79.642	625
PT	528374.21	719794.349							
LINE			N39°30'33"E	25.55					
END	528393.922	719810.605							

NOTES:

1. PROJECT CONTROL WAS ESTABLISHED USING GNSS, THE GLOBAL NAVIGATION SATELLITE SYSTEM.
2. THE SURVEY CONTROL DATA FOR THIS PROJECT HAS BEEN COMPILED FROM VARIOUS SOURCES. IF FURTHER INFORMATION REGARDING PROJECT CONTROL IS NEEDED, PLEASE CONTACT THE LOCATION AND SURVEYS UNIT.

HB-0030
 R/W 02C-1
 NORTH CAROLINA DEPARTMENT OF TRANSPORTATION

 PROFESSIONAL LAND SURVEYOR

 DOCUMENT NOT CONSIDERED FINAL UNLESS ALL SIGNATURES ARE COMPLETED
 2018 STANDARD SPECIFICATIONS

TIP Project: HB-0030
County: MACON

PREPARED FOR

 LOCATION AND SURVEYS UNIT
 PREPARED BY
 MATTERN AND CRAIG
 12 BROAD ST.
 ASHEVILLE NC 28801

PROPOSED ALIGNMENT CONTROL SHEET

HB-0030

R/W 020-1

NORTH CAROLINA
DEPARTMENT
OF TRANSPORTATION

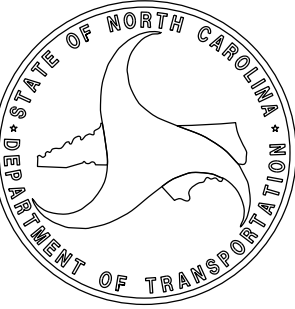

I, BRIAN BARWATT, PLS. CERTIFY THAT THE DATA
COMPILED CAME FROM AVAILABLE SURVEYS/MAPPING
PERFORMED BY OTHERS AND PROVIDED TO ME BY
NCDOT AND DO NOT CERTIFY TO THE ACCURACY OR
QUALITY OF THE INDIVIDUAL DATA SOURCES.

THIS 17TH DAY OF SEPTEMBER, 2025.

DocuSigned by:
Brian Barwatt

PROFESSIONAL LAND SURVEYOR L-4727

PROFESSIONAL LAND
SURVEYOR



DOCUMENT NOT CONSIDERED
FINAL UNLESS ALL SIGNATURES
ARE COMPLETED

2024 STANDARD
SPECIFICATIONS

TIP PROJECT: HB-0030
County: Macon

PREPARED FOR

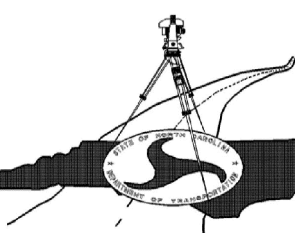

LOCATION AND
SURVEYS UNIT

PREPARED BY:
LOCATION AND SURVEY
DIVISION 14
122 RONNIE LANE
SYLVA, NC 28779

PROPOSED ALIGNMENT: L												
POINT	STATION	NORTHING	EASTING	BEARING	DIST	DELTA	D	L	T	R	LT	ST
START	10+00.00	527805.9297	718702.9324	N42°54'10.8"E	41.3383							
PC	10+41.34	527836.2103	718731.0738	N46°50'47.9"E	158.7329	07°53'14.2"	04°57'53.9"	158.8583	79.5548	1154.0000		
PT	12+00.20	527944.7762	718846.8735	N50°47'25.0"E	100.0866							
PC	13+00.28	528008.047	718924.4243	N53°00'21.7"E	117.1479	04°25'53.5"	03°46'54.8"	117.1771	58.6178	1515.0000		
PT	14+17.46	528078.5385	719017.9902	N55°13'18.4"E	16.7614							
PC	14+34.22	528088.0992	719031.7575	N65°02'36.2"E	119.4066	19°38'35.5"	16°22'12.8"	119.9934	60.5913	350.0000		
PT	15+54.22	528138.4807	719140.0148	N74°51'53.9"E	123.6684							
PC	16+77.88	528170.7698	719259.3935	N86°56'06.4"E	105.8091	24°08'25.0"	22°38'47.6"	106.5958	54.1006	253.0000		
PT	17+84.48	528176.4271	719365.0512	S80°59'41.1"E	65.9117							
PC	18+50.39	528166.1103	719430.1505	N79°43'38.9"E	139.9829	38°33'20.0"	27°01'34.7"	142.6594	74.1491	212.0000		
PCC	19+93.05	528191.0735	719567.8895	N57°14'28.8"E	84.9576	06°25'00.0"	07°32'55.9"	85.0020	42.5455	759.0000		
PT	20+78.05	528237.0442	719639.3353	N54°01'58.8"E	49.2824							
PC	21+27.33	528265.9887	719679.2223	N46°46'15.9"E	158.0065	14°31'25.8"	09°10'02.4"	158.4304	79.6421	625.0000		
PT	22+85.77	528374.2097	719794.3495	N39°30'33.1"E	25.5501							
END	23+11.32	528393.9222	719810.6045									

PROPOSED ALIGNMENT: DW1												
POINT	STATION	NORTHING	EASTING	BEARING	DIST	DELTA	D	L	T	R	LT	ST
START	10+00.00	528097.3409	719045.7710	S32°01'47.8"E	8.3887							
PC	10+08.39	528090.2292	719050.2201	S69°19'45.3"E	48.4783	74°35'54.9"	143°14'22.0"	52.0796	30.4711	40.0000		
PT	10+60.47	528073.1165	719095.5775	N73°22'17.3"E	49.5963							
PC	11+10.06	528087.3092	719143.0997	S75°26'27.3"E	41.4273	62°22'30.7"	143°14'22.0"	43.5461	24.2130	40.0000		
PT	11+53.61	528076.8953	719183.1968	S44°15'12.0"E	45.9212							
END	11+99.53	528044.0037	719215.2421									

NOTES:

1. THE PROPOSED ALIGNMENT CONTROL DATA FOR THIS PROJECT HAS BEEN COMPILED FROM VARIOUS SOURCES. IF FURTHER INFORMATION REGARDING PROJECT CONTROL IS NEEDED, PLEASE CONTACT THE LOCATION AND SURVEYS UNIT.

RIGHT OF WAY CONTROL SHEET

HB-0030

R/W 03E-1

NORTH CAROLINA
DEPARTMENT
OF TRANSPORTATION

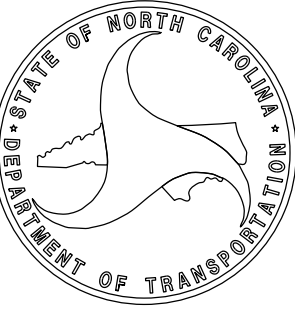

PROFESSIONAL LAND
SURVEYOR



DOCUMENT NOT CONSIDERED
FINAL UNLESS ALL SIGNATURES
ARE COMPLETED

2024 STANDARD
SPECIFICATIONS

I, BRIAN BARWATT, PLS, CERTIFY THAT THE RIGHT OF WAY AND PERMANENT EASEMENT MONUMENTATION FOR THIS PROJECT SHOWN HEREIN WAS COMPLETED UNDER MY DIRECT AND RESPONSIBLE CHARGE FROM AN ACTUAL SURVEY MADE UNDER MY SUPERVISION; THAT ALL HORIZONTAL CLOSURES HAD A MINIMUM RATIO OF PRECISION OF 1:10,000 (CLASS A). FIELD WORK WAS PERFORMED ON FEBRUARY 4TH, 2025, AND ALL COORDINATES ARE BASED ON NAD83/NA 2011; THAT THIS SURVEY WAS PERFORMED TO MEET THE REQUIREMENTS OF 21NCAC 56.1600 AS APPLICABLE.

THIS 17TH DAY OF SEPTEMBER, 2025.

DocuSigned by:
Brian Barwatt

PROFESSIONAL LAND SURVEYOR L-4727

PERMANENT ROW MARKER IRON PIN AND CAP: L			
STATION	OFFSET	NORTH	EAST
13+50.00	35.00	528011.0077	718984.6795
13+50.00	-35.00	528066.6690	718942.2316
13+50.00	-10.00	528046.7900	718957.3916
13+50.00	10.00	528030.8868	718969.5195
14+17.46	-35.00	528107.2863	718998.0262
14+17.46	35.00	528049.7907	719037.9543
14+34.22	35.00	528059.3514	719051.7215
14+34.22	-35.00	528116.8470	719011.7934
15+03.00	-35.00	528153.6382	719077.7622
15+03.00	-40.00	528158.2228	719075.7669
15+47.00	-35.00	528170.1156	719123.2371
15+47.00	-40.00	528174.9143	719121.8324
15+54.22	35.00	528104.6947	719149.1531
16+35.00	-35.00	528193.3592	719208.8592
16+35.00	-65.00	528222.3186	719201.0264
16+77.88	35.00	528136.9839	719268.5318
16+77.88	-65.00	528233.5152	719242.4223
17+40.00	35.00	528144.5077	719321.3881
17+84.48	-65.00	528240.6259	719375.2253
18+50.00	10.00	528156.2947	719428.1992
18+50.00	-65.00	528230.3703	719439.9386
18+50.00	-10.00	528176.0482	719431.3297

- NOT SET (IN ROCK)

- NOT SET (IN ROCK)

- 8" SPIKE

PERMANENT EASEMENT MARKER IRON PIN AND CAP: L			
STATION	OFFSET	NORTH	EAST
12+50.00	-21.00	527992.5315	718872.1877
12+50.00	-10.00	527984.0083	718879.1415
13+14.00	62.00	527968.2772	718973.8492
13+14.00	10.00	528008.8647	718941.3430
13+26.00	-38.00	528053.9816	718920.9689
13+50.00	-40.00	528070.6448	718939.1996
14+54.00	80.04	528030.6986	719090.1827
15+30.00	95.00	528041.5844	719147.9612
15+30.00	-75.00	528202.2266	719092.3368
15+90.00	35.00	528114.0380	719183.6968
15+90.00	65.00	528085.0786	719191.5296
16+30.00	-117.00	528271.2094	719182.6229
16+56.00	-112.00	528273.1713	719209.0266

- NOT SET (IN ROCK)

- NOT SET (IN WATER)

TIP PROJECT: HB-0030
County: Macon

PREPARED FOR

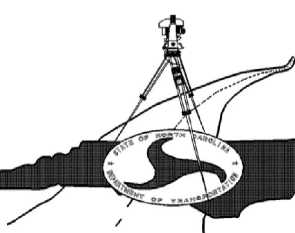

LOCATION AND
SURVEYS UNIT

PREPARED BY:
LOCATION AND SURVEYS
DIVISION 14
122 BONNIE LANE
SYLVA, NC 28779

NOTES:

1. IF FURTHER INFORMATION REGARDING PROJECT CONTROL IS NEEDED, PLEASE CONTACT THE LOCATION AND SURVEYS UNIT.

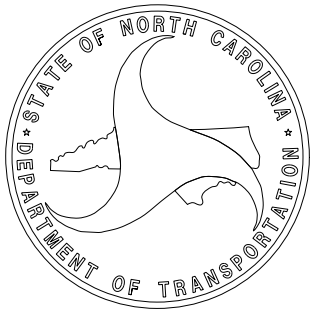

TIP PROJECT: HB-0030

County: Macon

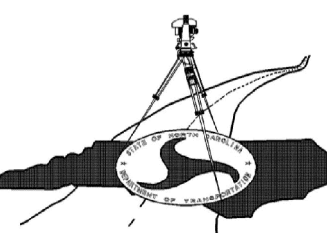

I, BRIAN BARWATT, PLS, CERTIFY THAT THE RIGHT OF WAY AND PERMANENT EASEMENT MONUMENTATION FOR THIS PROJECT SHOWN HEREIN WAS COMPLETED UNDER MY DIRECT AND RESPONSIBLE CHARGE FROM AN ACTUAL SURVEY MADE UNDER MY SUPERVISION; THAT ALL HORIZONTAL CLOSURES HAD A MINIMUM RATIO OF PRECISION OF 1:10,000 (CLASS A). FIELD WORK WAS PERFORMED FROM 2/20/2023 TO 4/10/2023, AND ALL COORDINATES ARE BASED ON NAD83/NA 2011; THAT THIS SURVEY WAS PERFORMED TO MEET THE REQUIREMENTS OF 21NCAC 56.1600 AS APPLICABLE.

THIS 17TH DAY OF SEPTEMBER, 2025.

DocuSigned by:
Brian Barwatt
43205F68A8AACE

PROFESSIONAL LAND SURVEYOR L-4727

- CUR DATA -L-**
Plc 11+20.89
Δc = 07°53'14.2" (RT)
D = 04°57'53.9"
Lc = 158.86
Tc = 79.55
R = 1,154
- CUR DATA -L-**
Plc 13+58.90
Δc = 04°25'53.5" (RT)
D = 03°46'54.8"
Lc = 117.18
Tc = 58.62
R = 1,515
- CUR DATA -L-**
Plc 14+94.81
Δc = 19°38'35.5" (RT)
D = 16°22'12.8"
Lc = 119.99
Tc = 60.59
R = 350
- CUR DATA -L-**
Plc 17+31.98
Δc = 24°08'25.0" (RT)
D = 22°38'47.6"
Lc = 106.60
Tc = 54.10
R = 253
- CUR DATA -L-**
Plc 19+24.54
Δc = 38°33'20.0" (LT)
D = 27°01'34.7"
Lc = 142.66
Tc = 74.15
R = 212
- CUR DATA -L-**
Plc 20+35.60
Δc = 06°25'00.0" (LT)
D = 07°32'55.9"
Lc = 85.00
Tc = 42.55
R = 759
- CUR DATA -L-**
Plc 22+06.98
Δc = 14°31'25.8" (LT)
D = 09°10'02.4"
Lc = 158.43
Tc = 79.64
R = 625

- CUR DATA -DW1-**
Plc 10+38.86
Δc = 74°35'54.9" (LT)
D = 143°14'22.0"
Lc = 52.08
Tc = 30.47
R = 40
- CUR DATA -DW1-**
Plc 11+34.28
Δc = 62°22'30.7" (RT)
D = 143°14'22.0"
Lc = 43.55
Tc = 24.21
R = 40

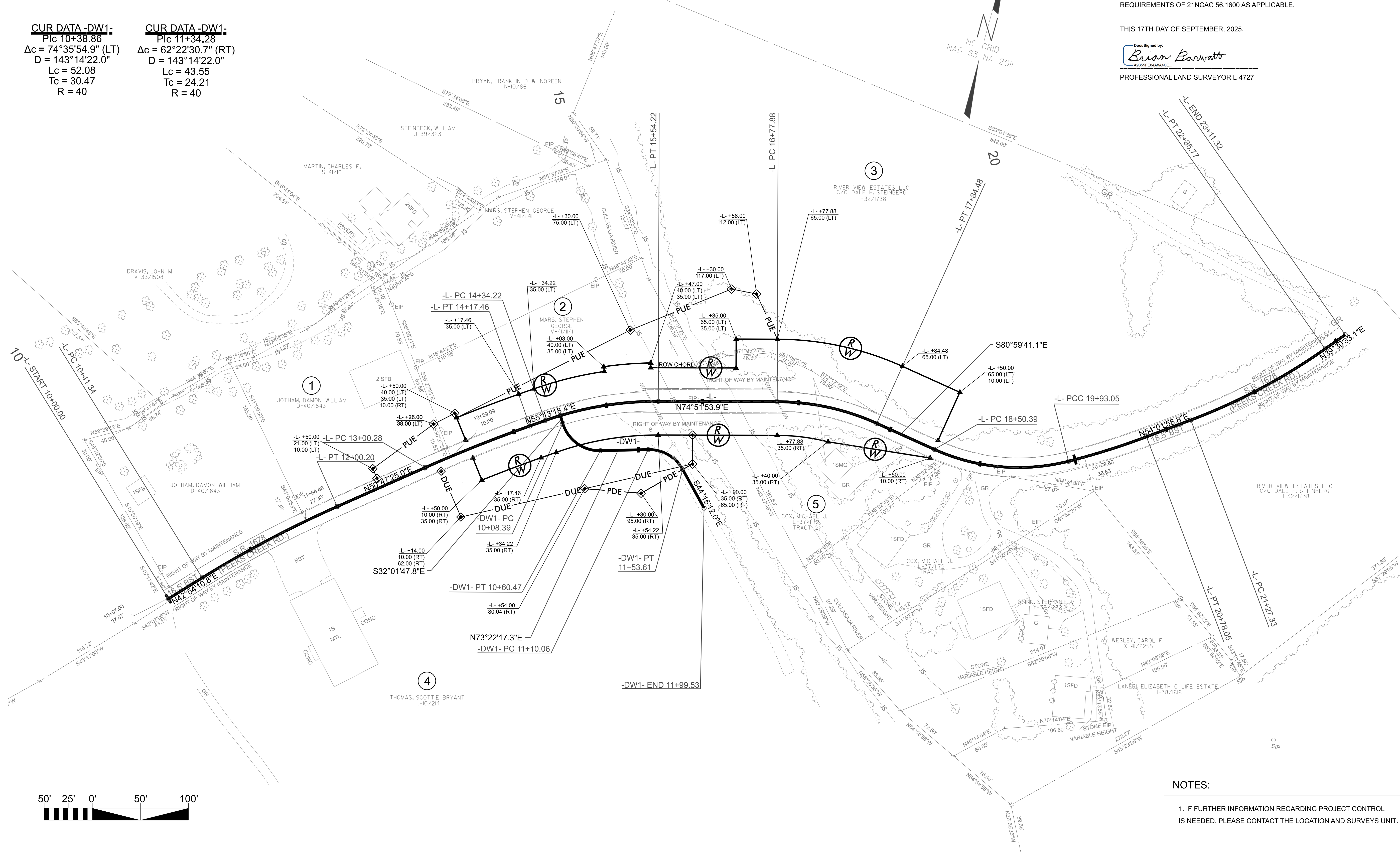

NOTES:

1. IF FURTHER INFORMATION REGARDING PROJECT CONTROL IS NEEDED, PLEASE CONTACT THE LOCATION AND SURVEYS UNIT.

STATE OF NORTH CAROLINA
DIVISION OF HIGHWAYS

TRANSPORTATION MANAGEMENT PLAN

MACON COUNTY

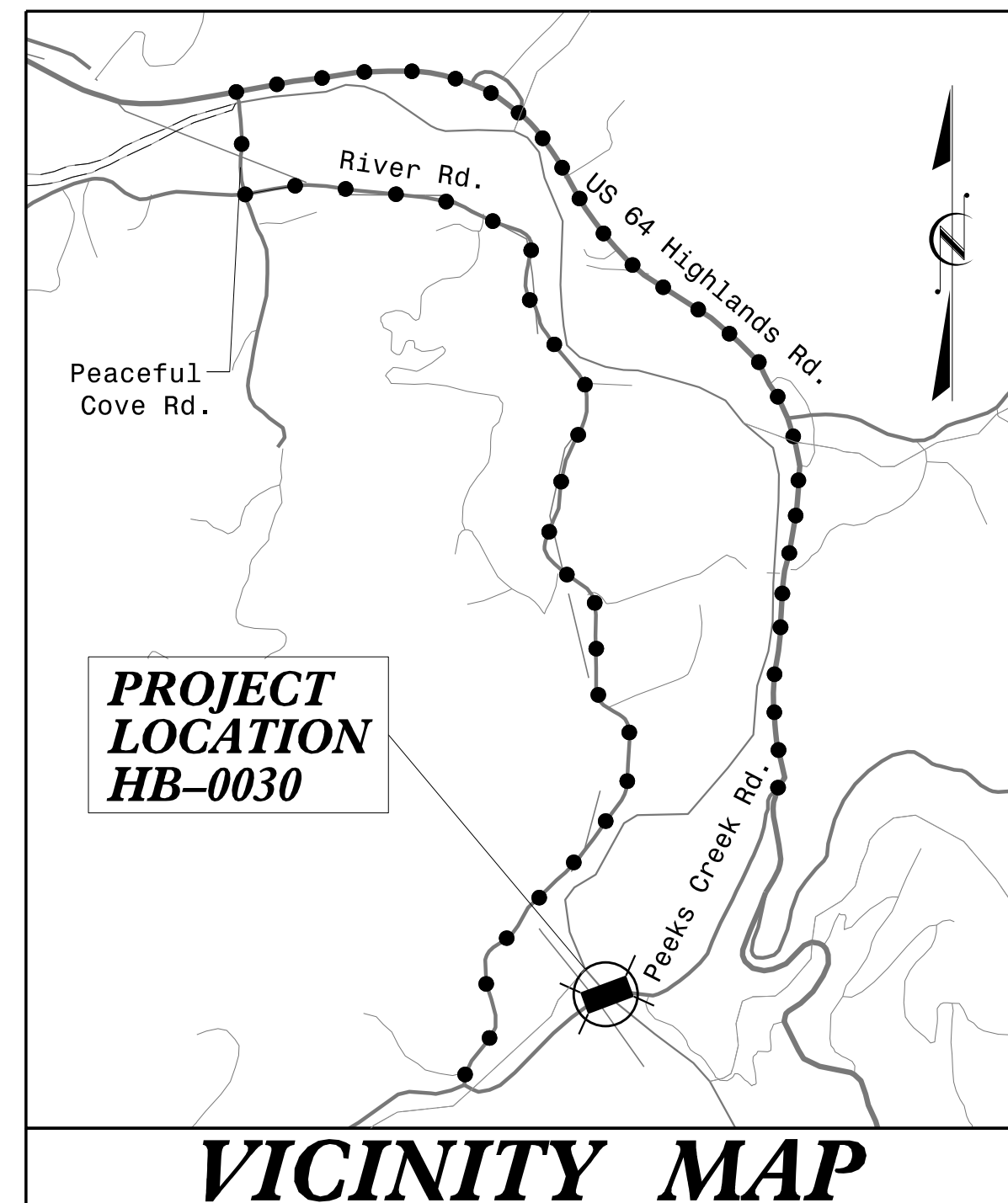
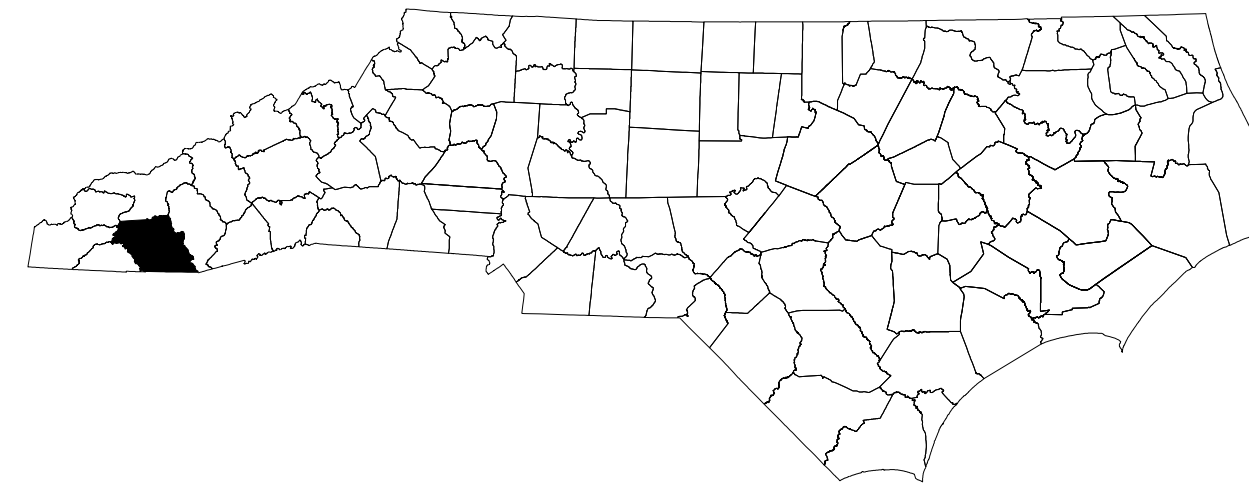

VICINITY MAP
NOT TO SCALE
●●●●● OFFSITE DETOUR

**LOCATION: REPLACE BRIDGE NO. 550055 ON SR 1679 (PEEKS CREEK RD)
OVER CULLASAJA RIVER**

TYPE OF WORK: GRADING, PAVING, DRAINAGE AND STRUCTURE

INDEX OF SHEETS

SHEET NO.	TITLE
TMP-1	TITLE SHEET, VICINITY MAP, AND INDEX OF SHEETS
TMP-1A	ROADWAY STANDARD DRAWINGS AND LEGEND
TMP-1B	TRANSPORTATION OPERATIONS PLAN & PHASING
TMP-2	SPECIAL SIGN DESIGN
TMP-3 TO TMP-4	OFF SITE DETOUR

SHEET NO.
TMP-1

5-SEP-2025 14:02
pw://drmp-pw/bentley.com/drmp-pw-01/Documents/Projects/2020/20-0464.031/HB-0030/CADD/HB-0030/Work Zone Traffic Control/HB-0030_TC_TCP_Titlesheet.dgn
AT RAL-TKLOTZ

<p>PLANS PREPARED BY:</p> <p>TIMOTHY A. KLOTZ, P.E. TRAFFIC CONTROL PROJECT ENGINEER</p> <p>KAYLEIGH A. FORBES, E.I. TRAFFIC CONTROL PROJECT DESIGN ENGINEER</p>	<p>PREPARED FOR:</p> <p>NCDOT DIVISION 14</p> <p>CONTACT: JARED BOND, PE 253 WEBSTER ROAD SYLVA, NC 28779</p>	<p>09/05/25 DATE SUBMITTED</p> <p>SUBMITTAL:</p> <p><input type="checkbox"/> STAGING CONCEPT</p> <p><input type="checkbox"/> MIDPOINT</p> <p><input type="checkbox"/> PRE-FINAL</p> <p><input checked="" type="checkbox"/> FINAL</p>
---	---	--

**DOCUMENT NOT CONSIDERED FINAL
UNLESS ALL SIGNATURES COMPLETED**



DRMP, INC.
5808 FARMINGTON PLACE
RALEIGH, NC 27609
(919) 872-5115

NC LICENSE NO. F-1524
www.drmp.com

APPROVED: *Timothy A. Klotz*

DATE: 10/7/2025

SEAL

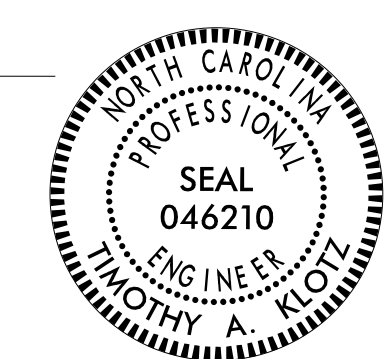

TIP PROJECT: HB-0030

ROADWAY STANDARD DRAWINGS

THE FOLLOWING ROADWAY STANDARDS AS SHOWN IN "ROADWAY STANDARD DRAWINGS" - N.C. DEPARTMENT OF TRANSPORTATION - RALEIGH, N.C., DATED JANUARY 2024 ARE APPLICABLE TO THIS PROJECT AND BY REFERENCE HEREBY ARE CONSIDERED A PART OF THESE PLANS:

STD. NO.	TITLE
1101.01	WORK ZONE WARNING SIGNS
1101.02	TEMPORARY LANE CLOSURES
1101.03	TEMPORARY ROAD CLOSURES
1101.11	TRAFFIC CONTROL DESIGN TABLES
1110.01	STATIONARY WORK ZONE SIGNS
1110.02	PORTABLE WORK ZONE SIGNS
1130.01	DRUMS
1135.01	CONES
1145.01	BARRICADES
1150.01	FLAGGERS
1180.01	SKINNY - DRUMS

LEGEND

GENERAL

- DIRECTION OF TRAFFIC FLOW
- DIRECTION OF PEDESTRIAN TRAFFIC FLOW
- EXIST. PVMT.
- NORTH ARROW
- PROPOSED PVMT.
- TEMP. SHORING (LOCATION PURPOSES ONLY)

WORK AREA

REMOVAL

SIGNALS

- EXISTING
- PROPOSED
- TEMPORARY
- PORTABLE

PAVEMENT MARKINGS

- EXISTING LINES
- TEMPORARY LINES

TRAFFIC CONTROL DEVICES

- BARRICADE (TYPE III)
- CONE
- DRUM
- SKINNY DRUM
- TUBULAR MARKER
- TEMPORARY CRASH CUSHION
- FLASHING ARROW BOARD
- FLAGGER
- LAW ENFORCEMENT
- TRUCK MOUNTED ATTENUATOR (TMA)
- CHANGEABLE MESSAGE SIGN

TEMPORARY SIGNING

- PORTABLE SIGN
- STATIONARY SIGN
- STATIONARY OR PORTABLE SIGN

PAVEMENT MARKERS

- CRYSTAL/CRYSTAL
- CRYSTAL/RED
- YELLOW/YELLOW

PAVEMENT MARKING SYMBOLS

- PAVEMENT MARKING SYMBOLS

5-SEP-2025 14:02
 pw://drmp-pw/bentley.com:drmp-pw-01/Documents/Projects/2020/20-0464.03/1180-0030/CADD/HB-0030/Work Zone Traffic Control/HB-0030-TC-TCP-T1180sheet.dgn
 AT RAL-TKLOTZ



APPROVED:
 DATE: 10/7/2025

SEAL

**DOCUMENT NOT CONSIDERED FINAL
UNLESS ALL SIGNATURES COMPLETED**

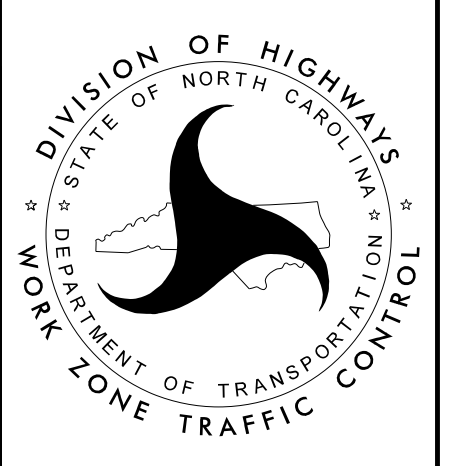
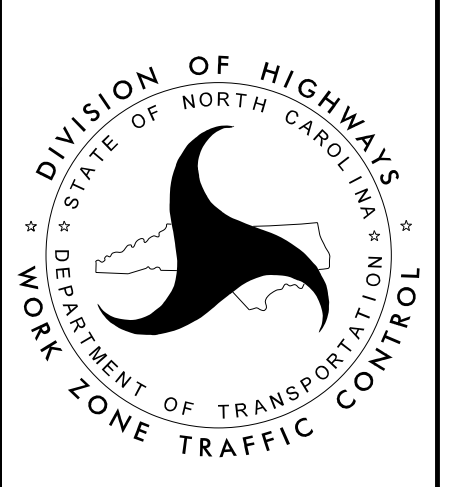

ROADWAY STANDARD DRAWINGS & LEGEND

MANAGEMENT STRATEGIES

DURING CONSTRUCTION OF PROPOSED STRUCTURE BRIDGE NO. 550055 OVER CULLASAJA RIVER, PEEKS CREEK ROAD WILL BE CLOSED TO THROUGH TRAFFIC. THROUGH TRAFFIC ON PEEKS CREEK ROAD WILL BE MAINTAINED USING AN OFF-SITE DETOUR.

OFF-SITE DETOUR WILL UTILIZE US 64, PEACEFUL COVE ROAD AND RIVER ROAD. ACCESS TO RESIDENTIAL DRIVEWAYS WILL BE MAINTAINED USING FLAGGERS AS NECESSARY.

GENERAL NOTES

CHANGES MAY BE REQUIRED WHEN PHYSICAL DIMENSIONS IN THE DETAIL DRAWINGS, STANDARD DETAILS, AND ROADWAY DETAILS ARE NOT ATTAINABLE TO MEET FIELD CONDITIONS OR RESULT IN DUPLICATE OR UNDESIRE OVERLAPPING OF DEVICES. MODIFICATION MAY INCLUDE: MOVING, SUPPLEMENTING, COVERING, OR REMOVAL OF DEVICES AS DIRECTED BY THE ENGINEER.

THE FOLLOWING GENERAL NOTES APPLY AT ALL TIMES FOR THE DURATION OF THE CONSTRUCTION PROJECT EXCEPT WHEN OTHERWISE NOTED IN THE PLAN OR DIRECTED BY THE ENGINEER.

LANE AND SHOULDER CLOSURE REQUIREMENTS

- A) REMOVE LANE CLOSURE DEVICES FROM THE LANE WHEN WORK IS NOT BEING PERFORMED BEHIND THE LANE CLOSURE OR WHEN A LANE CLOSURE IS NO LONGER NEEDED OR AS DIRECTED BY THE ENGINEER.
- B) WHEN PERSONNEL AND/OR EQUIPMENT ARE WORKING WITHIN 15 FT OF AN OPEN TRAVEL LANE, CLOSE THE NEAREST OPEN SHOULDER USING ROADWAY STANDARD DRAWING NO. 1101.04 UNLESS THE WORK AREA IS PROTECTED BY BARRIER OR GUARDRAIL OR A LANE CLOSURE IS INSTALLED.
- C) WHEN PERSONNEL AND/OR EQUIPMENT ARE WORKING WITHIN 5 FT OF AN OPEN TRAVEL LANE ON AN UNDIVIDED FACILITY, CLOSE THE NEAREST OPEN TRAVEL LANE USING ROADWAY STANDARD DRAWING NO. 1101.02 UNLESS THE WORK AREA IS PROTECTED BY BARRIER OR GUARDRAIL.
- D) WHEN PERSONNEL AND/OR EQUIPMENT ARE WORKING WITHIN A LANE OF TRAVEL OF AN UNDIVIDED FACILITY, CLOSE THE LANE ACCORDING TO THE TRAFFIC CONTROL PLANS, ROADWAY STANDARD DRAWINGS, OR AS DIRECTED BY THE ENGINEER. CONDUCT THE WORK SO THAT ALL PERSONNEL AND/OR EQUIPMENT REMAIN WITHIN THE CLOSED TRAVEL LANE.
- E) DO NOT WORK SIMULTANEOUSLY WITHIN 15 FT ON BOTH SIDES OF AN OPEN TRAVELWAY, RAMP, OR LOOP WITHIN THE SAME LOCATION UNLESS PROTECTED WITH GUARDRAIL OR BARRIER.

PAVEMENT EDGE DROP OFF REQUIREMENTS

- F) BACKFILL AT A 6:1 SLOPE UP TO THE EDGE AND ELEVATION OF EXISTING PAVEMENT IN AREAS ADJACENT TO AN OPENED TRAVEL LANE THAT HAS AN EDGE OF PAVEMENT DROP-OFF AS FOLLOWS:

BACKFILL DROP-OFFS THAT EXCEED 3 INCHES ON ROADWAYS WITH POSTED SPEED LIMITS LESS THAN 45 MPH.

BACKFILL WITH SUITABLE COMPACTED MATERIAL, AS APPROVED BY THE ENGINEER, AT NO EXPENSE TO THE DEPARTMENT.
- G) DO NOT EXCEED A DIFFERENCE OF 2 INCHES IN ELEVATION BETWEEN OPEN LANES OF TRAFFIC FOR NOMINAL LIFTS OF 1.5 INCHES. INSTALL ADVANCE WARNING "UNEVEN LANES" SIGNS (W8-11) 350' IN ADVANCE AND A MINIMUM OF EVERY HALF MILE THROUGHOUT THE UNEVEN AREA.

GENERAL NOTES CONT.

TRAFFIC PATTERN ALTERATIONS

H) NOTIFY THE ENGINEER THIRTY (30) CALENDAR DAYS PRIOR TO ANY TRAFFIC PATTERN ALTERATION.

SIGNING

I) INSTALL ADVANCE WORK ZONE WARNING SIGNS WHEN WORK IS WITHIN 40 FT FROM THE EDGE OF TRAVEL LANE AND NO MORE THAN THREE (3) DAYS PRIOR TO THE BEGINNING OF CONSTRUCTION.

J) PROVIDE SIGNING AND DEVICES REQUIRED TO CLOSE THE ROAD ACCORDING TO THE ROADWAY STANDARD DRAWINGS AND TRAFFIC CONTROL PLANS.

PROVIDE SIGNING REQUIRED FOR THE OFF-SITE DETOUR ROUTE AS SHOWN IN THE TRAFFIC CONTROL PLANS.

K) COVER OR REMOVE ALL SIGNS AND DEVICES REQUIRED TO CLOSE THE ROAD WHEN ROAD CLOSURE IS NOT IN OPERATION.

COVER OR REMOVE ALL SIGNS REQUIRED FOR THE OFF-SITE DETOUR WHEN THE THE DETOUR IS NOT IN OPERATION.

L) ENSURE ALL NECESSARY SIGNING IS IN PLACE PRIOR TO ALTERING ANY TRAFFIC PATTERN.

M) INSTALL BLACK ON ORANGE "DIP" SIGNS (W8-2) AND/OR "BUMP" SIGNS (W8-1) 350' IN ADVANCE OF THE UNEVEN AREA, OR AS DIRECTED BY THE ENGINEER.

TRAFFIC CONTROL DEVICES

N) WHEN LANE CLOSURES ARE NOT IN EFFECT SPACE CHANNELIZING DEVICES IN WORK AREAS NO GREATER IN FEET THAN TWICE THE POSTED SPEED LIMIT (MPH) EXCEPT, 10 FT ON-CENTER IN RADII, AND 3 FT OFF THE EDGE OF AN OPEN TRAVELWAY. REFER TO STANDARD SPECIFICATIONS FOR ROADS AND STRUCTURES SECTIONS 1130 (DRUMS), 1135 (CONES) AND 1180 (SKINNY DRUMS) FOR ADDITIONAL REQUIREMENTS.

O) PLACE TYPE III BARRICADES, WITH "ROAD CLOSED" SIGN R11-2 ATTACHED, OF SUFFICIENT LENGTH TO CLOSE ENTIRE ROADWAY.

PAVEMENT MARKINGS AND MARKERS

P) TIE PROPOSED PAVEMENT MARKING LINES TO EXISTING PAVEMENT MARKING LINES.

MISCELLANEOUS

Q) IN THE EVENT A TIE-IN CANNOT BE MADE IN ONE DAY'S TIME, BRING THE TIE-IN AREA TO AN APPROPRIATE ROADWAY ELEVATION AS DETERMINED BY THE ENGINEER. PLACE BLACK ON ORANGE "LOOSE GRAVEL" SIGNS (W8-7) AND BLACK ON ORANGE "PAVEMENT ENDS" SIGNS (W8-3) 350' AND 700' RESPECTIVELY IN ADVANCE OF THE UNEVEN AREAS. USE DRUMS TO DELINEATE THE EDGE OF ROADWAY ALONG UNPAVED AREAS.

PHASING

FOR THE DURATION OF CONSTRUCTION, ENSURE ALL DRIVEWAY ACCESS IS MAINTAINED. CONTRACTOR WILL USE SKINNY DRUMS TO MAINTAIN DRIVEWAY ACCESS AS NECESSARY.

PHASE 1:

STEP 1:

INSTALL WORK ZONE ADVANCE WARNING SIGNS. SEE RSD 1101.01, SHEET 3 OF 3.

INSTALL DETOUR SIGNAGE FOR SR 1679 (PEEKS CREEK ROAD). ONCE INSTALLED, COVER AND BAG SIGNAGE UNTIL SHIFTING INTO THE PHASE I - STEP 2 LONG TERM TRAFFIC PATTERN. SEE SHEETS TMP-2 THRU TMP-4 FOR DETOUR SIGNAGE.

STEP 2:

ONCE ALL DETOUR SIGNAGE IS INSTALLED AND THE CONTRACTOR IS READY FOR CONSTRUCTION, USING RSD 1101.03 SHEET 1 OF 9 AND SHEETS TMP-2 THRU TMP-4, UNBAG DETOUR SIGNAGE AND USE TYPE III BARRICADES TO CLOSE SR 1679 (PEEKS CREEK ROAD) TO THROUGH TRAFFIC.

RELOCATE AND REMOVE EXISTING SIGNING ACCORDING TO SIGNING PLANS AS NEEDED FOR CONSTRUCTION.

STEP 3:

MAINTAIN ALL NECESSARY BARRICADES AND DETOUR SIGNAGE ASSOCIATED WITH THE DETOUR FOR SR 1679 (PEEKS CREEK ROAD).

BEHIND BARRICADES AND AWAY FROM TRAFFIC, REMOVE THE EXISTING STRUCTURE. CONSTRUCT THE PROPOSED STRUCTURE.

USING RSD 1101.02 SHEET 1 OF 19 AS NECESSARY, CONSTRUCT -L- FROM STA 13+50 +/- TO STA 18+50 +/-.

STEP 4:

MAINTAIN ALL NECESSARY BARRICADES AND DETOUR SIGNAGE ASSOCIATED WITH THE DETOUR FOR SR 1679 (PEEKS CREEK ROAD).

COMPLETE ANY REMAINING PAVING, INCLUDING FINAL SURFACE COURSE AND INSTALL FINAL PAVEMENT MARKINGS AND MARKERS. SEE PAVEMENT MARKING PLAN FOR MORE DETAILS.

INSTALL FINAL SIGNAGE. SEE SIGNING PLAN FOR MORE DETAILS.

AFTER THE COMPLETION OF THE PROJECT, CONTRACTOR SHALL REMOVE ALL REMAINING DETOUR SIGNAGE AND BARRICADES ASSOCIATED WITH THE DETOUR FOR SR 1679 (PEEKS CREEK ROAD) AND ALL REMAINING TRAFFIC CONTROL DEVICES TO ALLOW NORMAL TRAFFIC OPERATION.

5-SEP-2025 14:40:21
pw://drmp-pw/bentley.com:drmp-pw-01/Documents/Projects/2020/20-0464.03/1679/0030/Work Zone Traffic Control/HB-0030-TC_TCP_T1Hesheet.dgn
TKLOTZ AT RAL-TKLOTZ



APPROVED: *Timothy A. Klotz*
DATE: 10/7/2025

**DOCUMENT NOT CONSIDERED FINAL
UNLESS ALL SIGNATURES COMPLETED**

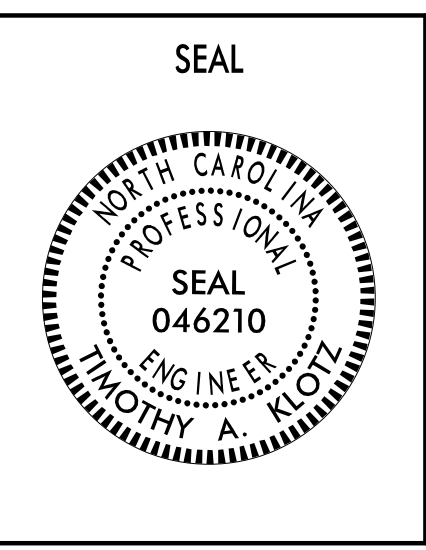

TRANSPORTATION OPERATIONS PLAN & PHASING

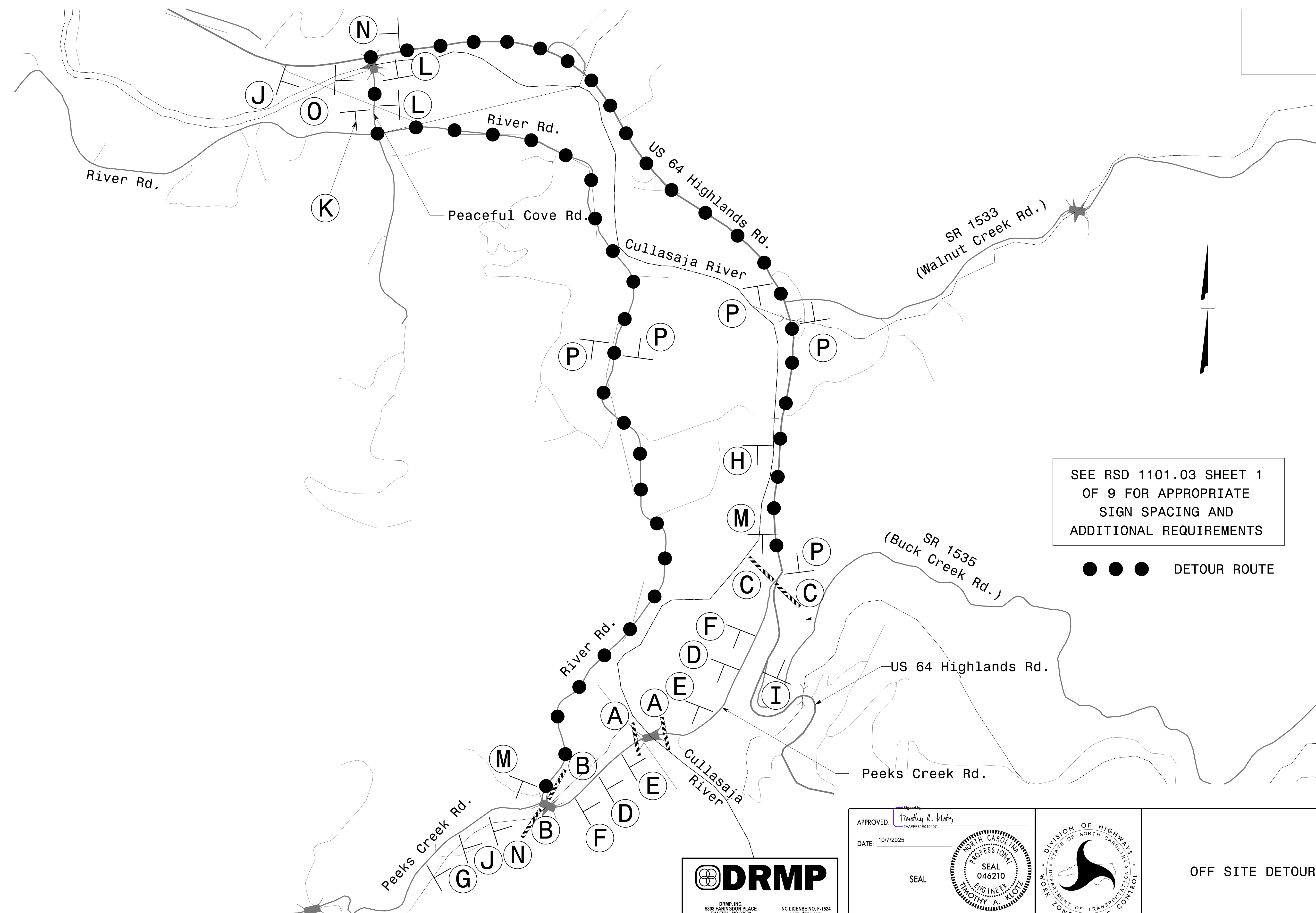

SEE RSD 1101.03 SHEET 1
OF 9 FOR APPROPRIATE
SIGN SPACING AND
ADDITIONAL REQUIREMENTS

● ● ● DETOUR ROUTE

5-SEP-2025 14:02
 pw://drmp-pw.bentley.com:drmp-pw-01/Documents/Projects/2020/20-0464.031/HB-0030/CADD/HB-0030/Work Zone Traffic Control/HB-0030_TC_TCP_Detour.dgn
 AT RAL-TKLOTZ

DRMP
 DRMP, INC.
 5808 FARRINGTON PLACE
 RALEIGH, NC 27609
 (919) 872-5115
 NC LICENSE NO. F-1524
 www.drmp.com

APPROVED: *Timothy A. Klotz*
 DATE: 10/7/2025
 SEAL
 DOCUMENT NOT CONSIDERED FINAL
 UNLESS ALL SIGNATURES COMPLETED

DIVISION OF HIGHWAYS
 STATE OF NORTH CAROLINA
 DEPARTMENT OF TRANSPORTATION
 WORK ZONE TRAFFIC CONTROL

OFF SITE DETOUR

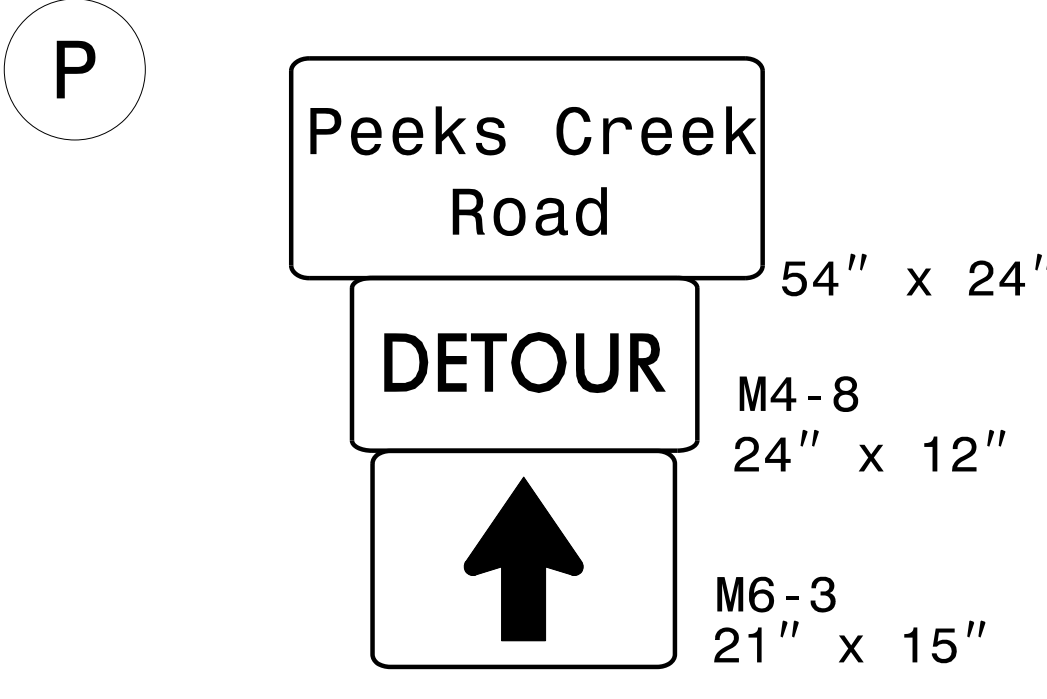
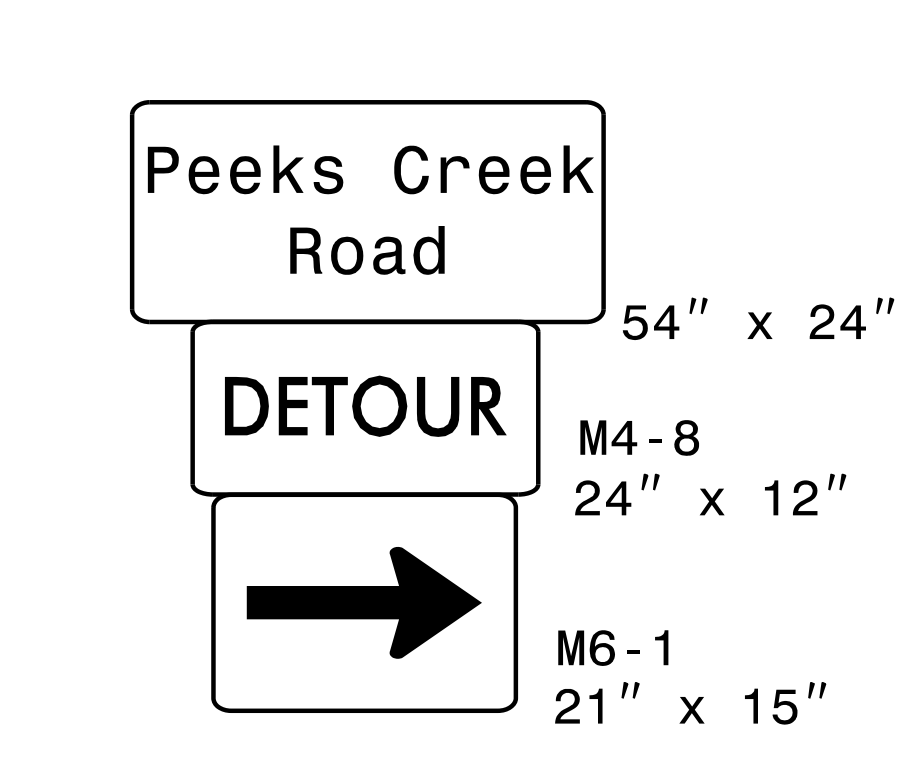
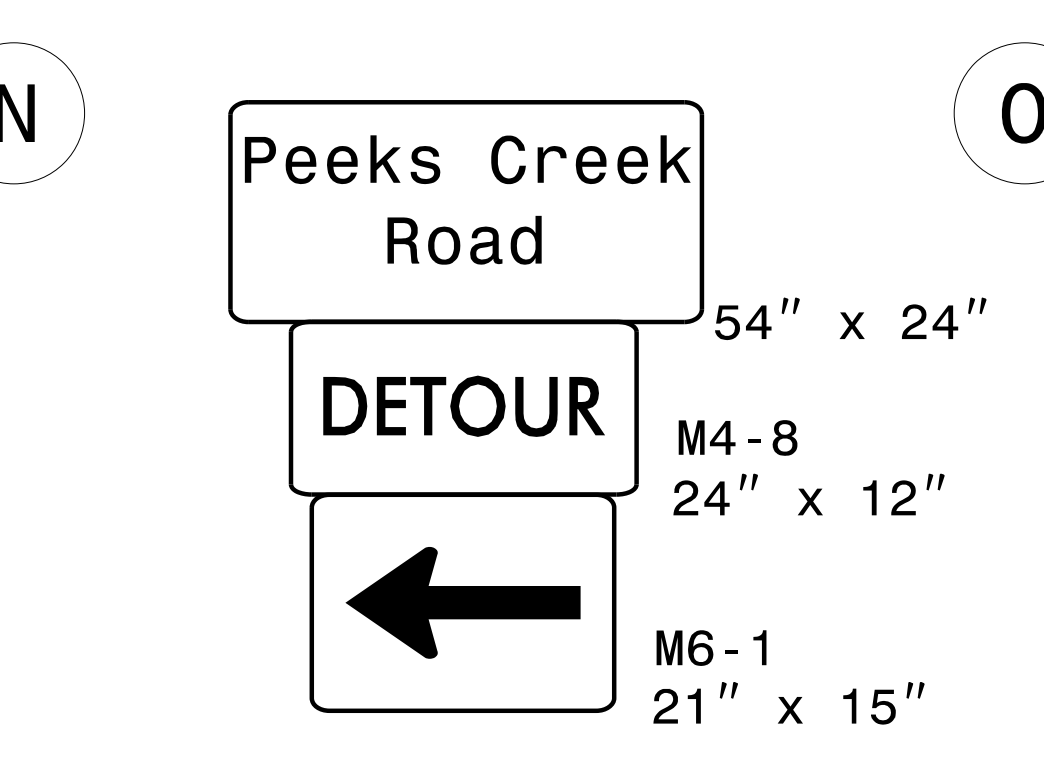
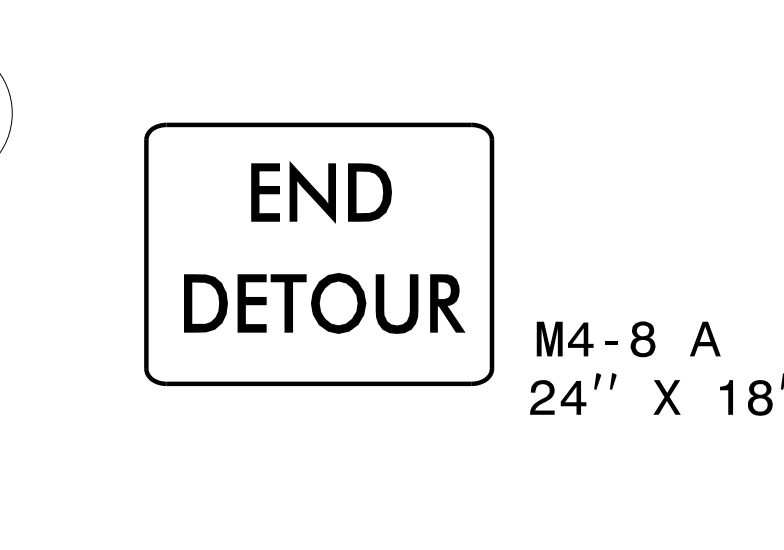
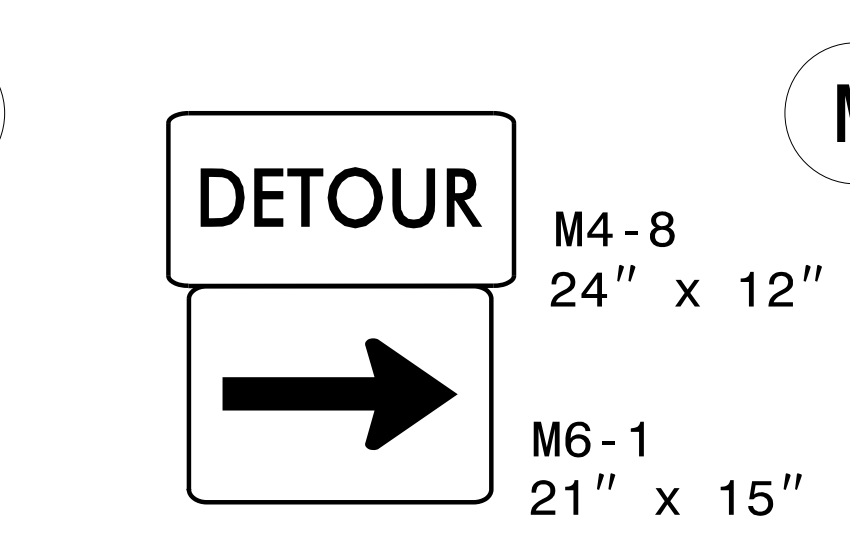
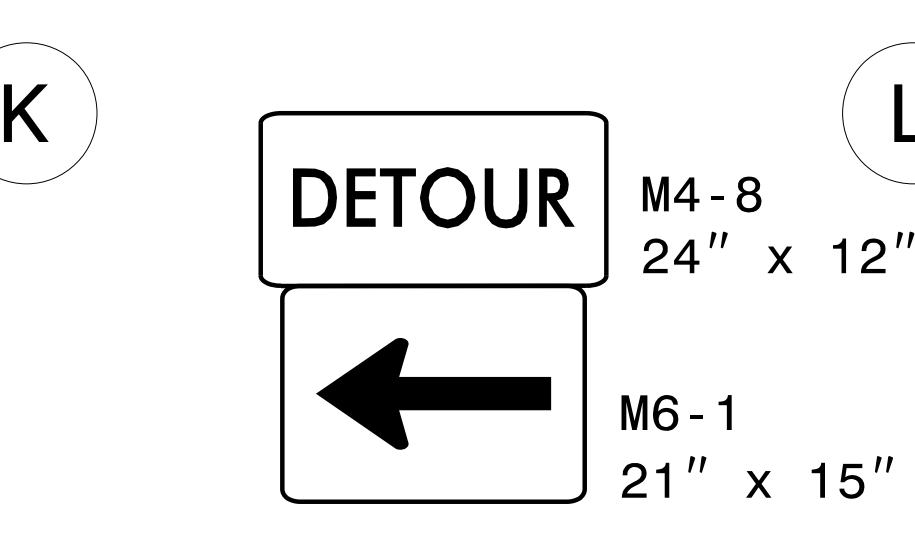
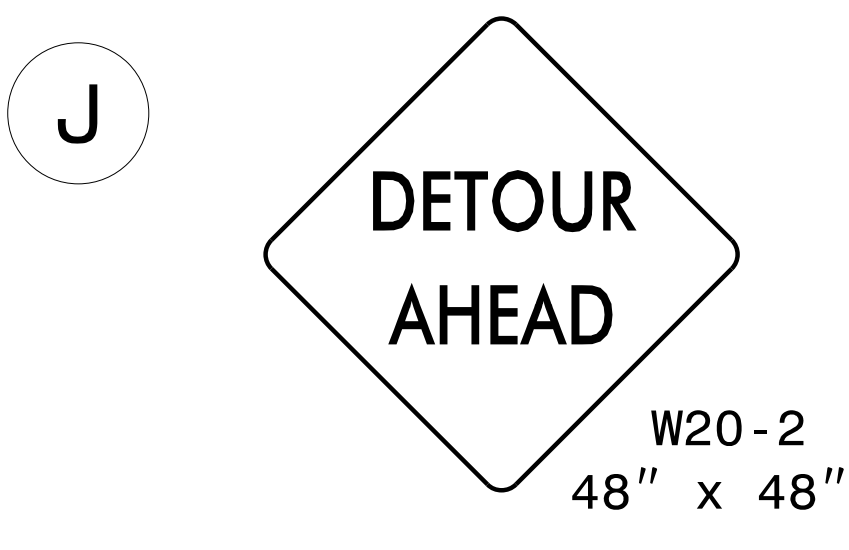
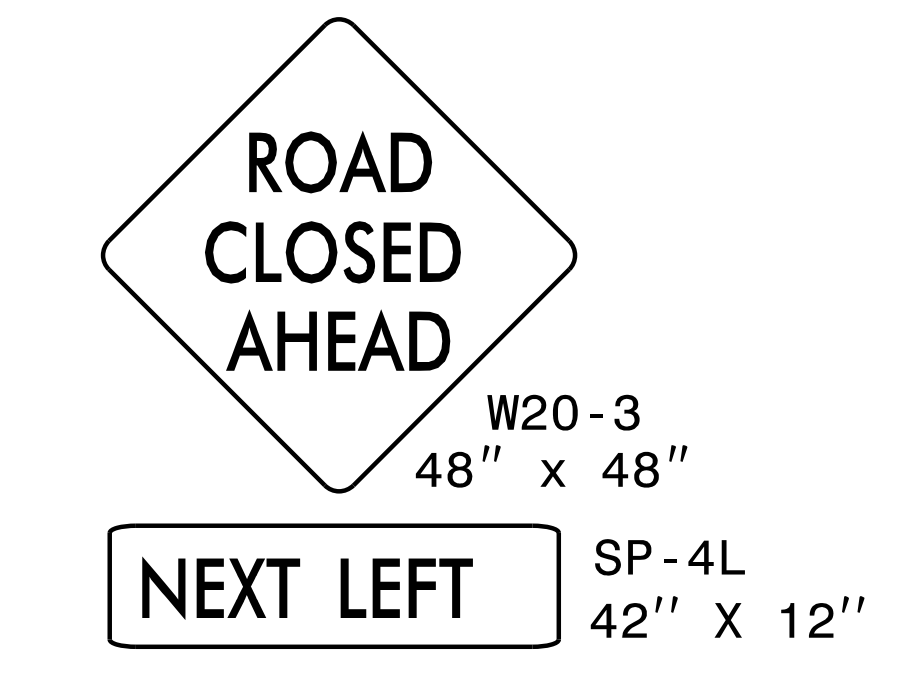
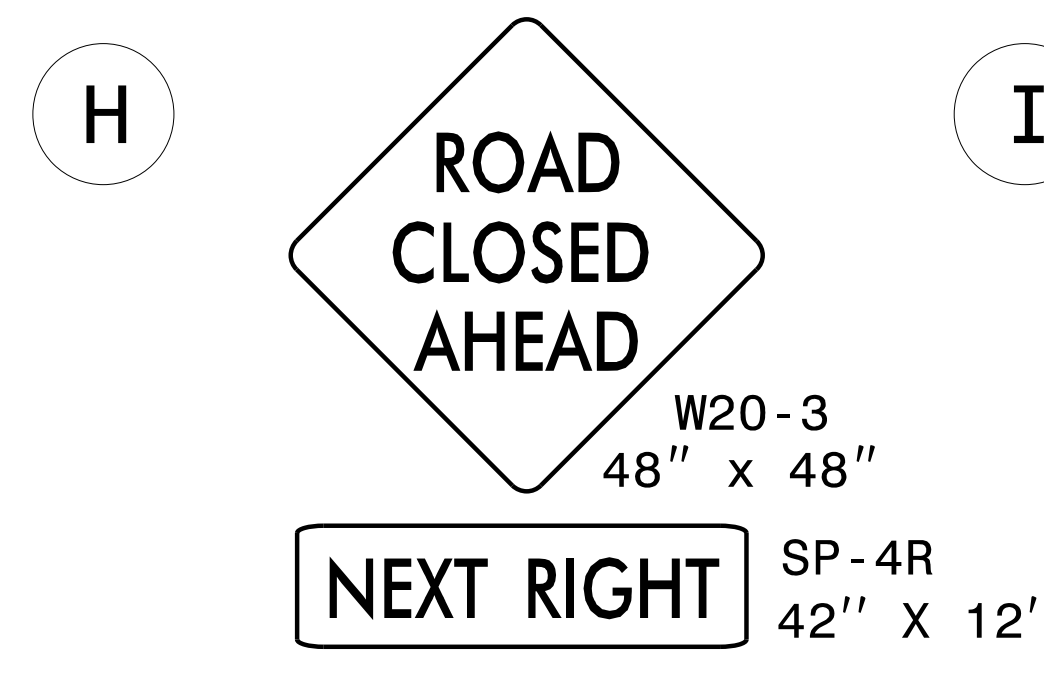
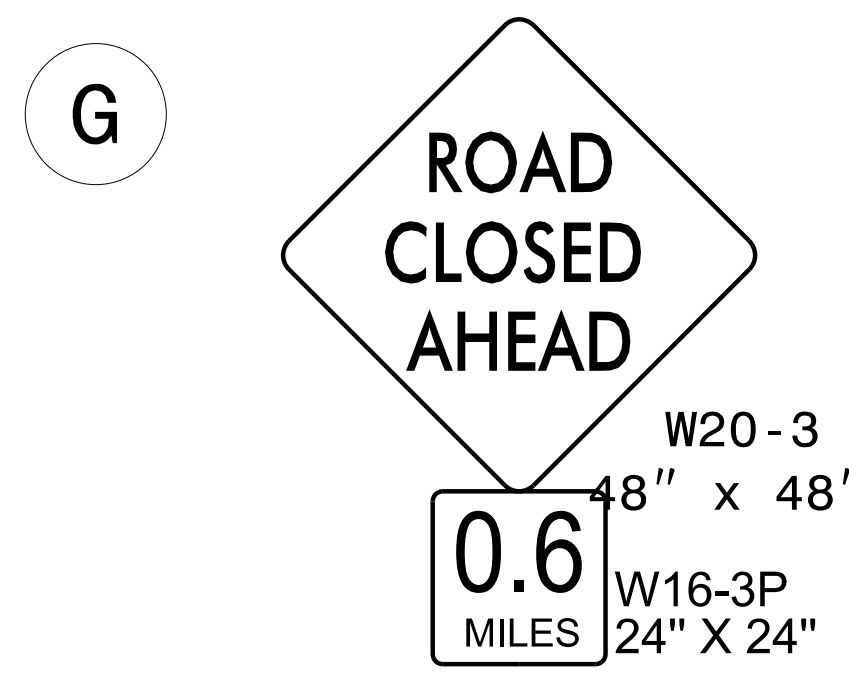
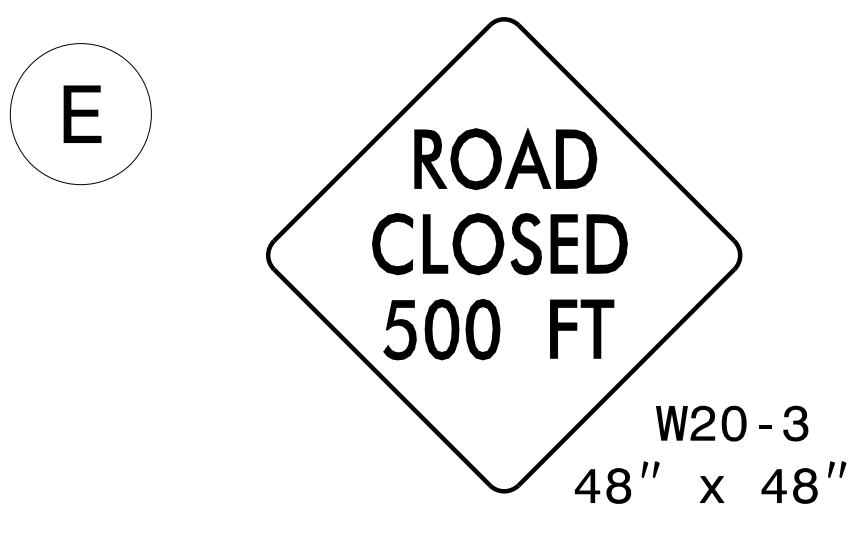
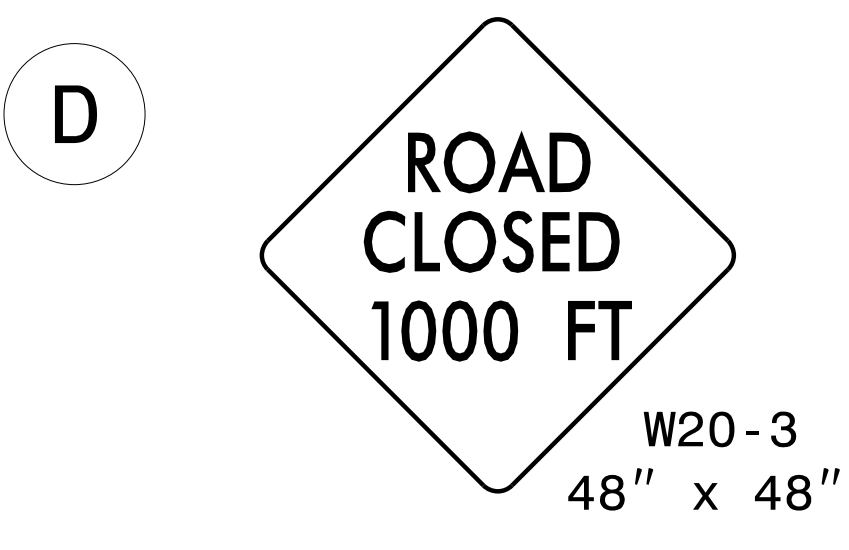
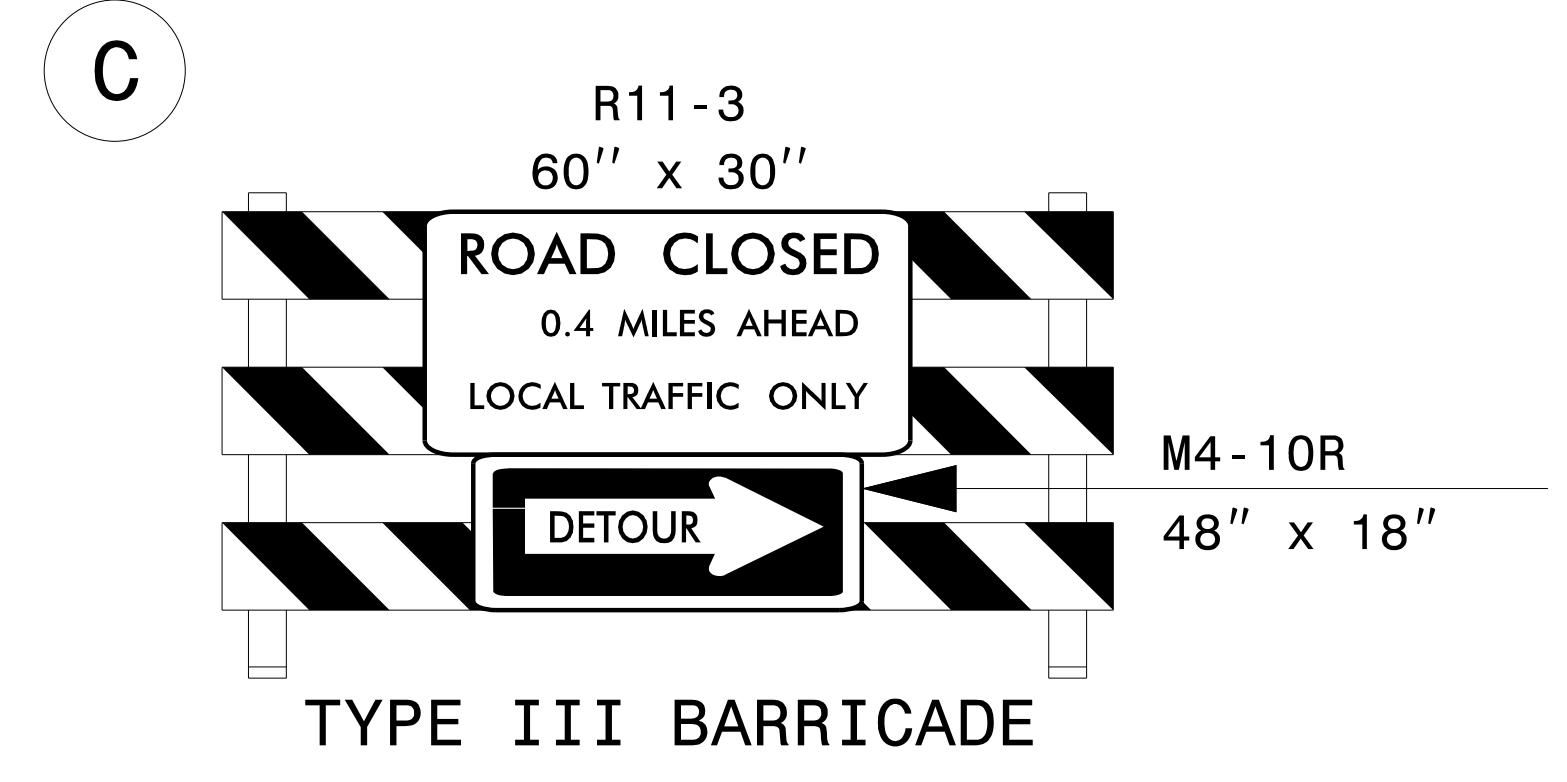
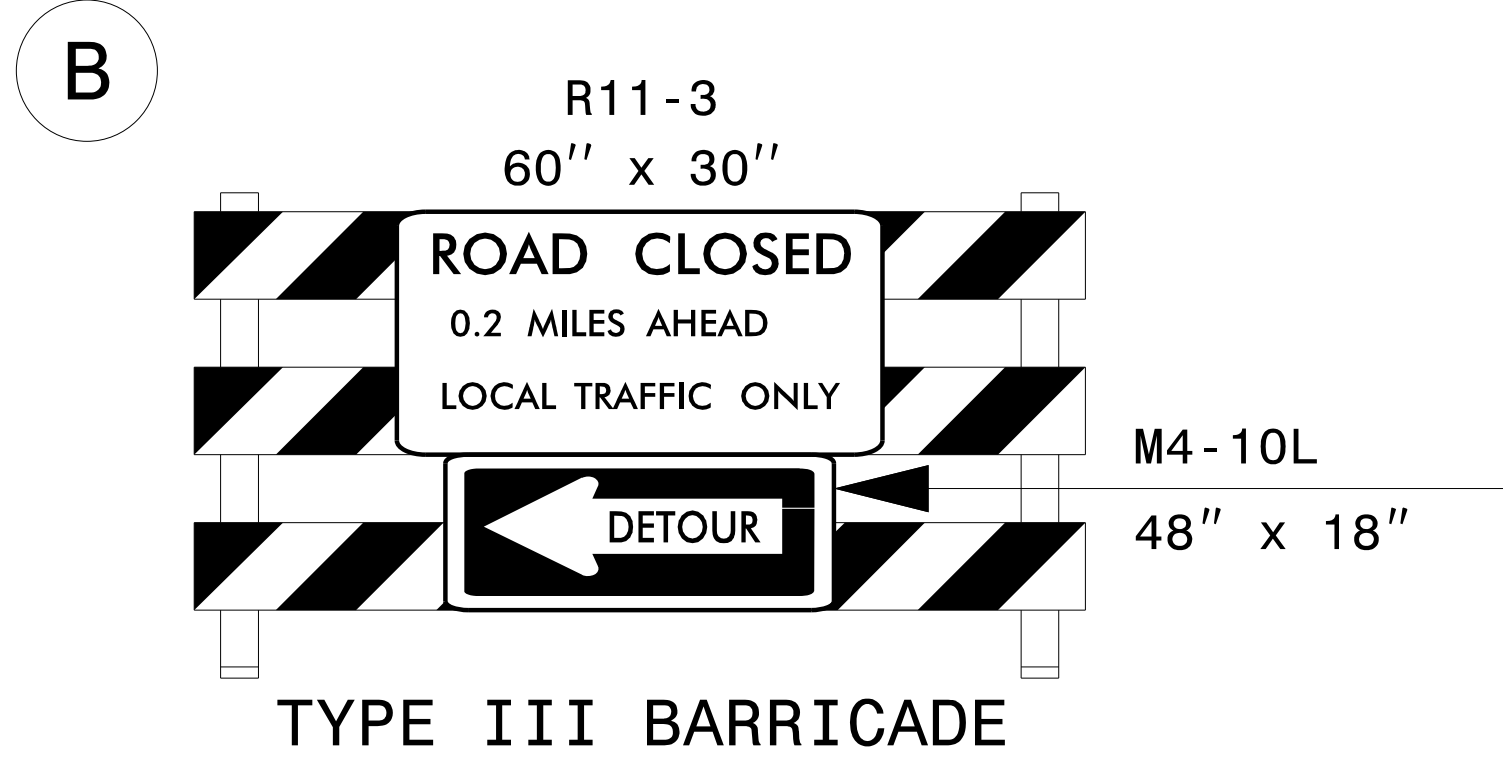
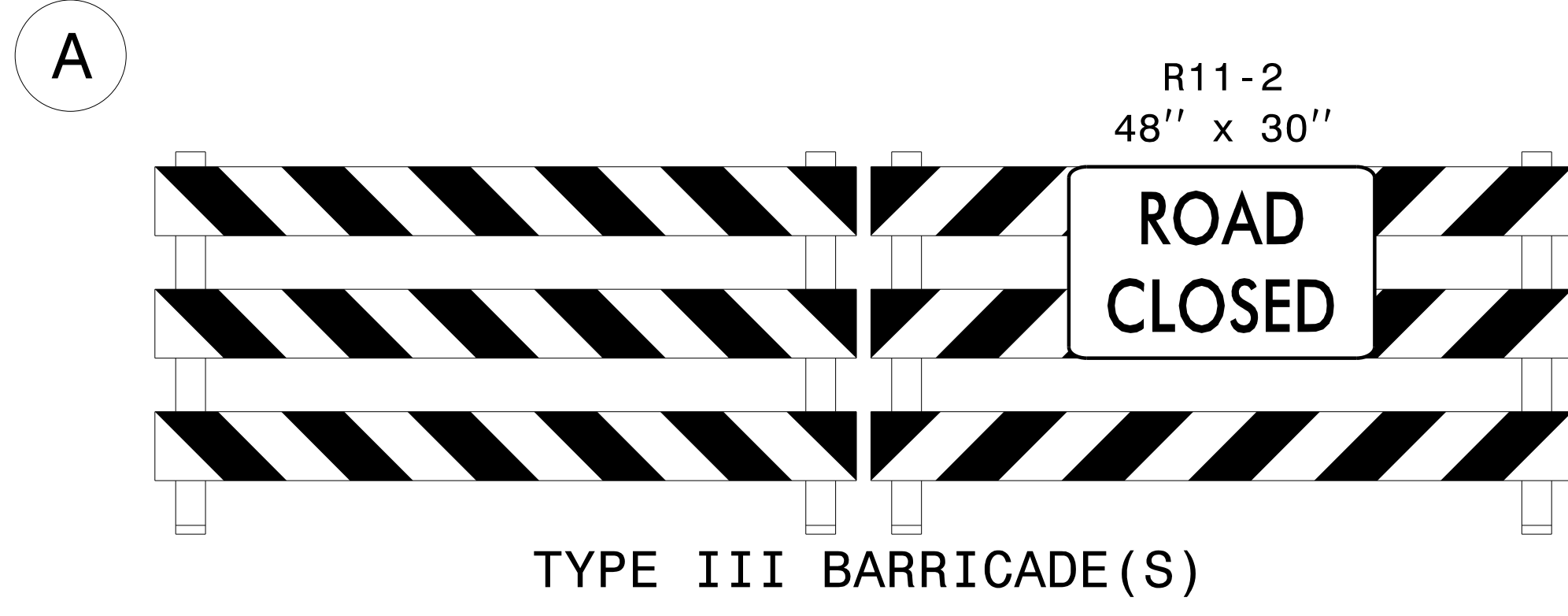

5-SEP-2025 14:02 P:\7\drmp-pw\benley.com\drmp-pw-01\Documents\Projects\2020\20-0464.03\HB-0030\CADD\HB-0030\Work Zone Traffic Control\HB-0030_TC_TCP_Detour.dgn AT RAL-TKLOTZ

<p>DRMP, INC. 5805 FARNSWORTH PLACE RALEIGH, NC 27609 (919) 872-5115</p> <p>NC LICENSE NO. F-1524 www.drmp.com</p>	<p>APPROVED: <i>Timothy A. Klotz</i></p> <p>DATE: 10/7/2025</p> <p>SEAL</p>			<p>OFF SITE DETOUR</p>
	<p>DOCUMENT NOT CONSIDERED FINAL UNLESS ALL SIGNATURES COMPLETED</p>			

DIVISION OF HIGHWAYS STATE OF NORTH CAROLINA

PROJECT REFERENCE NO. HB-0030	SHEET NO. EC-02
ROADWAY DESIGN ENGINEER	HYDRAULICS ENGINEER

EROSION & SEDIMENT CONTROL LEGEND

Std. #	Description	Symbol	Std. #	Description	Symbol
1605.01	Temporary Silt Fence		1633.01	Temporary Rock Silt Check Type A	
1606.01	Special Sediment Control Fence		1633.02	Temporary Rock Silt Check Type B	
1622.01	Temporary Berms and Slope Drains		1633.03	Temporary Rock Silt Check Type A with Excelsior Matting and Flocculant	
1630.02	Silt Basin Type B		1634.01	Temporary Rock Sediment Dam Type A	
1630.03	Temporary Silt Ditch		1634.02	Temporary Rock Sediment Dam Type B	
1630.04	Stilling Basin		1635.01	Rock Pipe Inlet Sediment Trap Type A	
1630.05	Temporary Diversion		1635.02	Rock Pipe Inlet Sediment Trap Type B	
1630.06	Special Stilling Basin		1636.01	Excelsior Wattle Check	
1630.07	Skimmer Basin		1636.01	Excelsior Wattle Check with Flocculant	
1630.08	Tiered Skimmer Basin		1636.01	Coir Fiber Wattle Check	
1630.09	Earthen Dam with Skimmer		1636.01	Coir Fiber Wattle Check with Flocculant	
	Infiltration Basin		1636.02	Silt Fence Excelsior Wattle Break	
	Rock Inlet Sediment Trap:			Silt Fence Coir Fiber Wattle Break	
1632.01	Type A		1636.03	Excelsior Wattle Barrier	
1632.02	Type B		1636.03	Coir Fiber Wattle Barrier	
1632.03	Type C				

PROJECT REFERENCE NO. <i>HB-0030</i>	SHEET NO. <i>EC-2A</i>
ROADWAY DESIGN ENGINEER	HYDRAULICS ENGINEER

ONSITE CONCRETE WASHOUT STRUCTURE WITH LINER

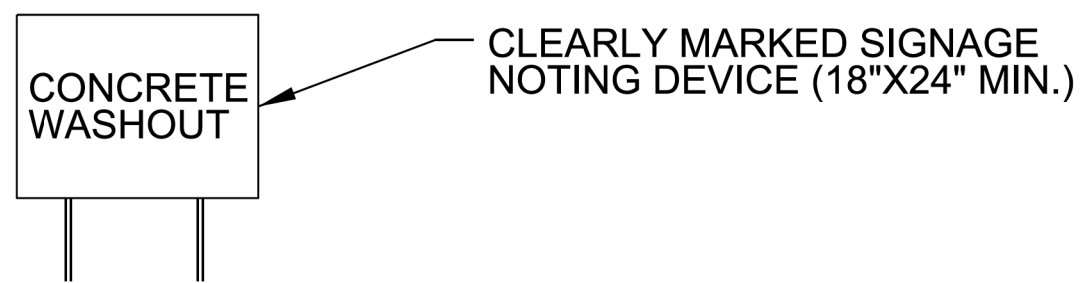
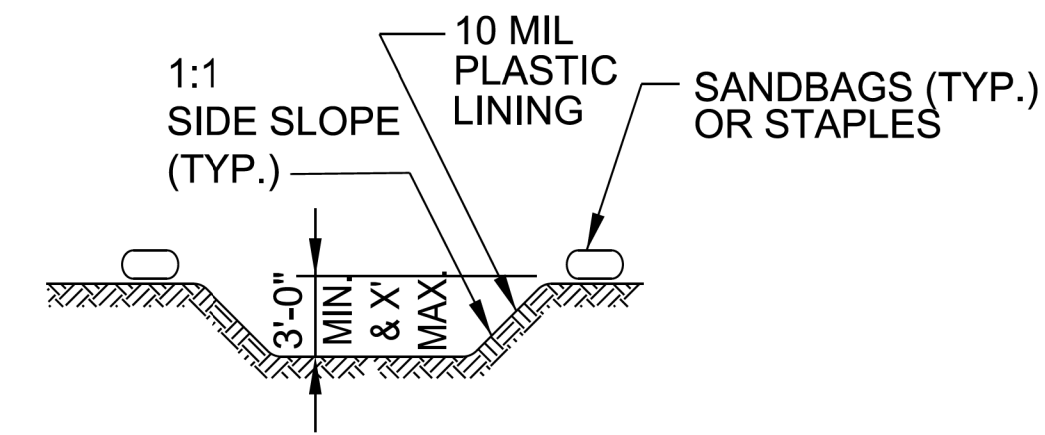
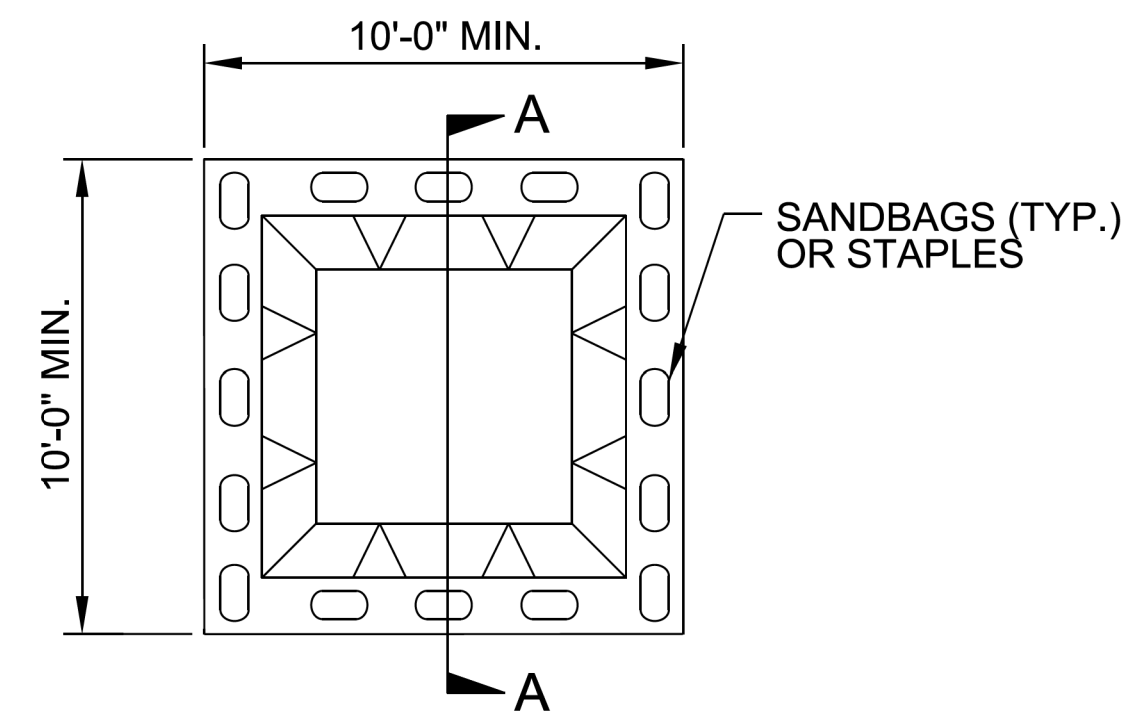

SECTION A-A

- NOTES:**
1. ACTUAL LOCATION DETERMINED IN FIELD
 2. THE CONCRETE WASHOUT STRUCTURES SHALL BE MAINTAINED WHEN THE LIQUID AND/OR SOLID REACHES 75% OF THE STRUCTURES CAPACITY.
 3. CONCRETE WASHOUT STRUCTURE NEEDS TO BE CLEARLY MARKED WITH SIGNAGE NOTING DEVICE.

PLAN

BELOW GRADE WASHOUT STRUCTURE

NOT TO SCALE

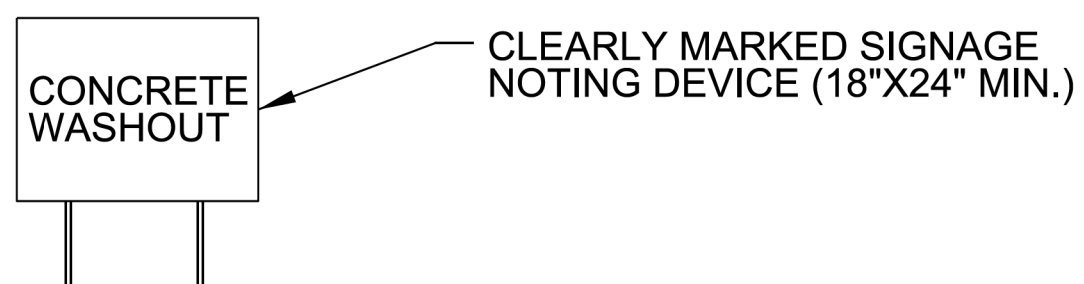
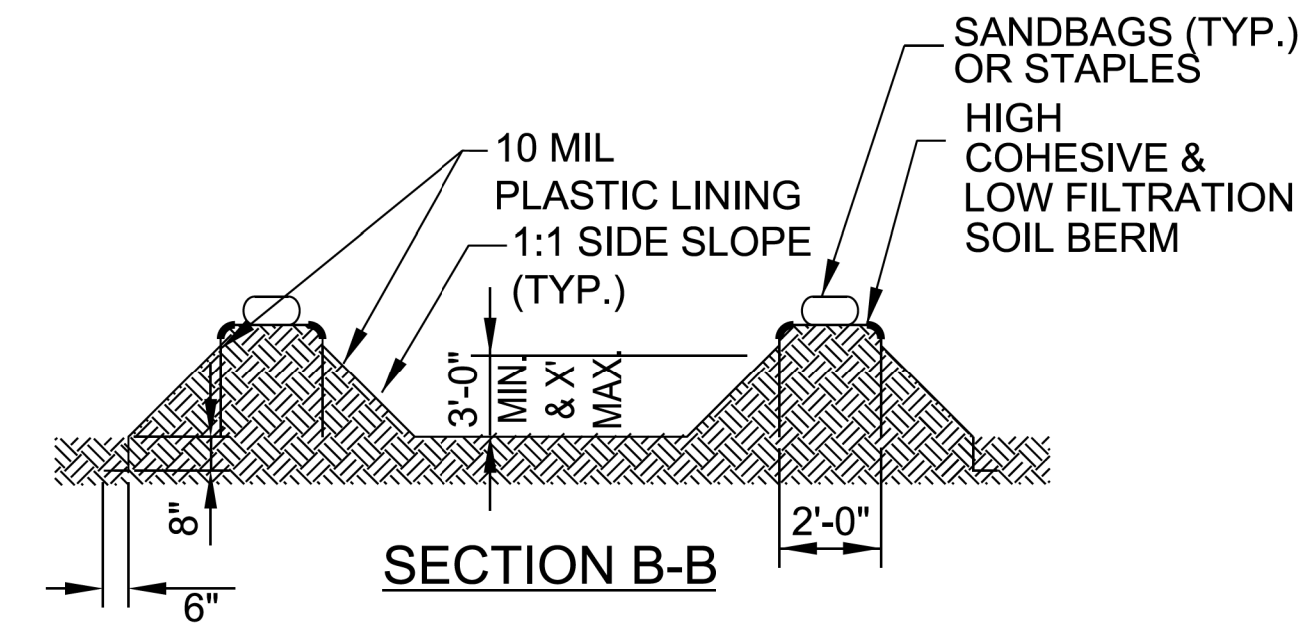
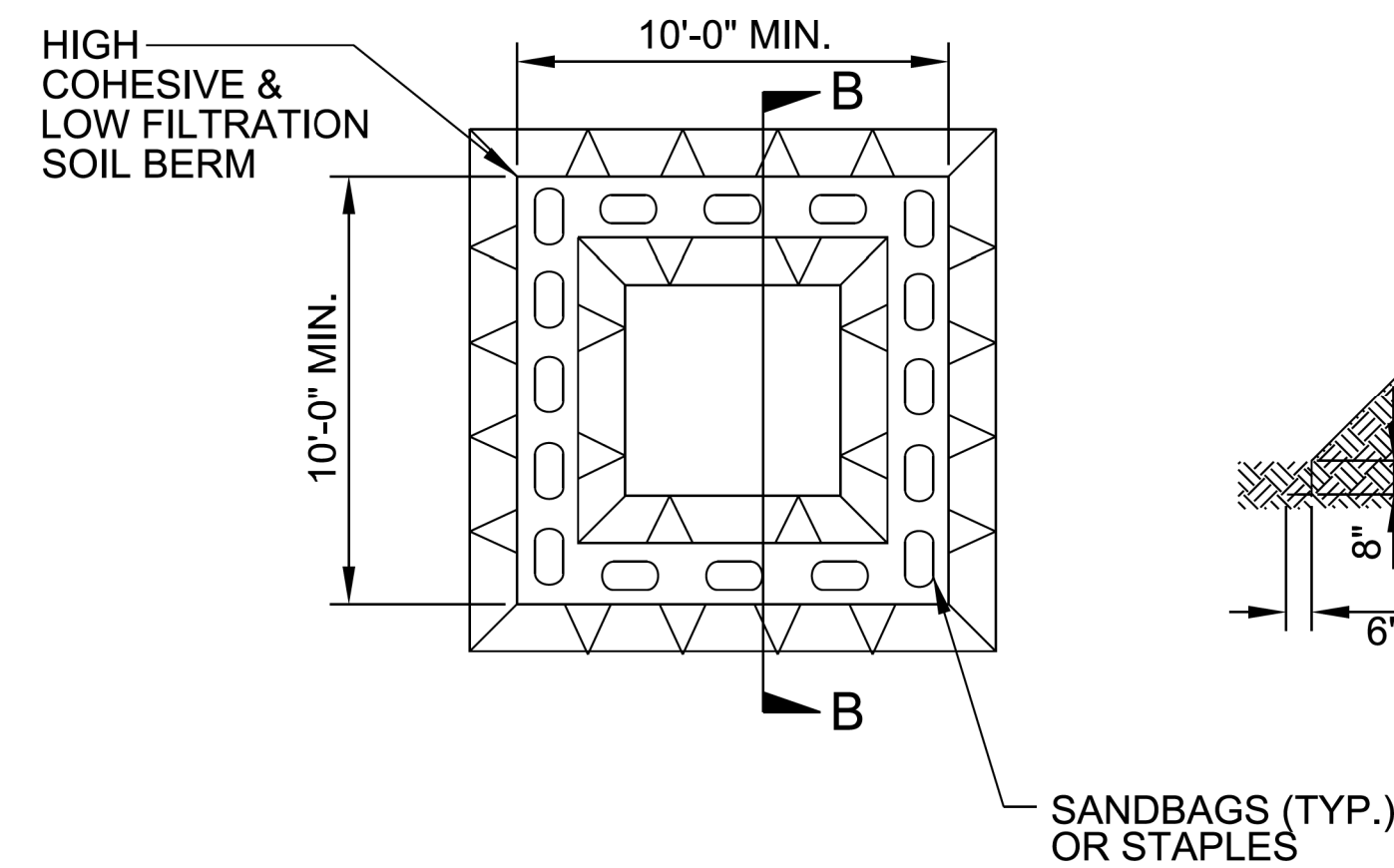

- NOTES:**
1. ACTUAL LOCATION DETERMINED IN FIELD
 2. THE CONCRETE WASHOUT STRUCTURES SHALL BE MAINTAINED WHEN THE LIQUID AND/OR SOLID REACHES 75% OF THE STRUCTURES CAPACITY TO PROVIDE ADEQUATE HOLDING CAPACITY WITH A MINIMUM 12 INCHES OF FREEBOARD.
 3. CONCRETE WASHOUT STRUCTURE NEEDS TO BE CLEARLY MARKED WITH SIGNAGE NOTING DEVICE.

PLAN

ABOVE GRADE WASHOUT STRUCTURE

NOT TO SCALE

DIVISION OF HIGHWAYS
STATE OF NORTH CAROLINA

PROJECT REFERENCE NO. <i>HB-0030</i>	SHEET NO. <i>EC-3A</i>
ROADWAY DESIGN ENGINEER	HYDRAULICS ENGINEER

SOIL STABILIZATION TIMEFRAMES

<i>SITE DESCRIPTION</i>	<i>STABILIZATION TIME</i>	<i>TIMEFRAME EXCEPTIONS</i>
PERIMETER DIKES, SWALES, DITCHES AND SLOPES	7 DAYS	NONE
HIGH QUALITY WATER (HQW) ZONES	7 DAYS	NONE
SLOPES STEEPER THAN 3:1	7 DAYS	IF SLOPES ARE 10' OR LESS IN LENGTH AND ARE NOT STEEPER THAN 2:1, 14 DAYS ARE ALLOWED.
SLOPES 3:1 TO 4:1	14 DAYS	7 DAYS FOR SLOPES GREATER THAN 50' IN LENGTH WITH SLOPES STEEPER THAN 4:1. 7 DAYS FOR PERIMETER DIKES, SWALES, DITCHES PERIMETER SLOPES, AND HQW ZONES
ALL OTHER AREAS WITH SLOPES FLATTER THAN 4:1	14 DAYS	7 DAYS FOR PERIMETER DIKES, SWALES, DITCHES PERIMETER SLOPES, AND HQW ZONES

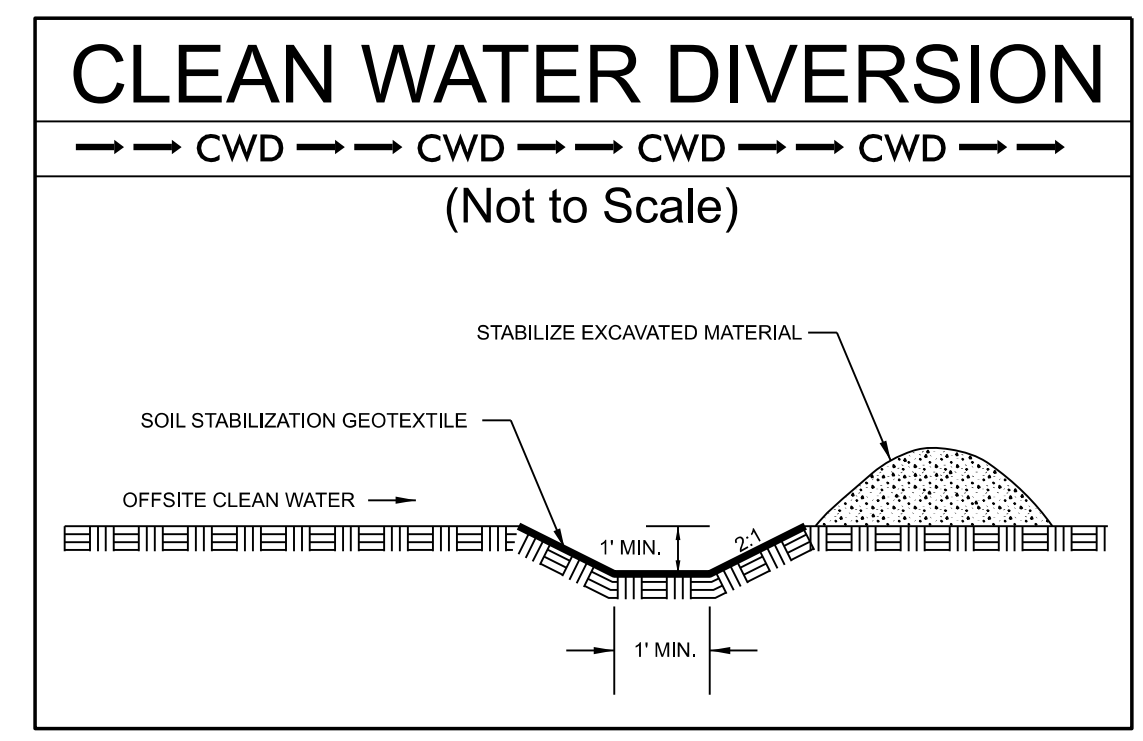
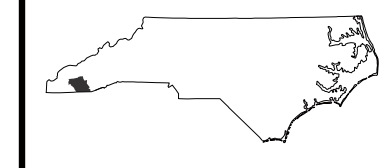

CUR DATA -L- Plc 11+20.89 $\Delta c = 07^{\circ}53'14.2''$ (RT) D = $04^{\circ}57'53.9''$ Lc = 158.86 Tc = 79.55 R = 1.154 SE = EXIST.	CUR DATA -L- Plc 13+58.90 $\Delta c = 04^{\circ}25'53.5''$ (RT) D = $03^{\circ}46'54.8''$ Lc = 117.18 Tc = 58.62 R = 1.515 SE = EXIST.	CUR DATA -L- Plc 14+94.81 $\Delta c = 19^{\circ}38'35.5''$ (RT) D = $16^{\circ}22'12.8''$ Lc = 119.99 Tc = 60.59 R = 350 SE = 0.040 R.O. = 60' DS = 30 MPH	CUR DATA -L- Plc 17+31.98 $\Delta c = 24^{\circ}08'25.0''$ (RT) D = $22^{\circ}38'47.6''$ Lc = 106.60 Tc = 54.10 R = 253 SE = 0.040 R.O. = 60' DS = 30 MPH	CUR DATA -L- Plc 19+24.54 $\Delta c = 38^{\circ}33'20.0''$ (LT) D = $27^{\circ}01'34.7''$ Lc = 142.66 Tc = 74.15 R = 212 SE = EXIST.	CUR DATA -L- Plc 20+35.60 $\Delta c = 06^{\circ}25'00.0''$ (LT) D = $07^{\circ}32'55.9''$ Lc = 85.00 Tc = 42.55 R = 759 SE = EXIST.	CUR DATA -L- Plc 22+06.98 $\Delta c = 14^{\circ}31'25.8''$ (LT) D = $09^{\circ}10'02.4''$ Lc = 158.43 Tc = 79.64 R = 625 SE = EXIST.
--	--	--	--	--	---	--

CUR DATA -DW1- Plc 10+38.86 $\Delta c = 74^{\circ}35'54.9''$ (LT) D = $143^{\circ}14'22.0''$ Lc = 52.08 Tc = 30.47 R = 40 SE = NC	CUR DATA -DW1- Plc 11+34.28 $\Delta c = 62^{\circ}22'30.7''$ (RT) D = $143^{\circ}14'22.0''$ Lc = 43.55 Tc = 24.21 R = 40 SE = NC
---	---

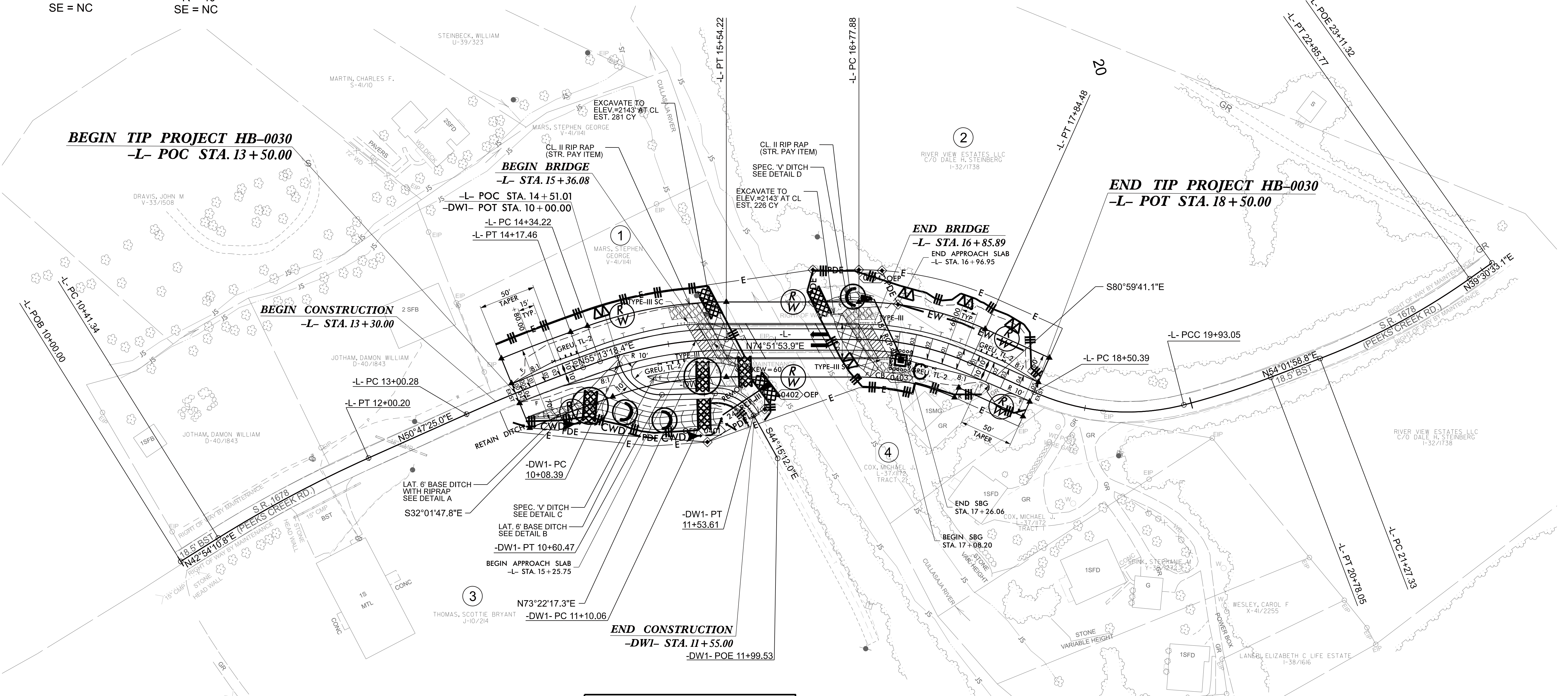

Place Matting for Erosion Control on Slope as Work Allows. Sta. 17+00 to Sta. 18+25

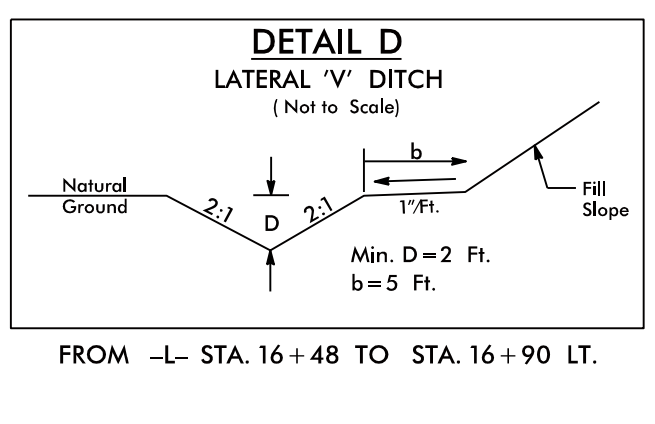
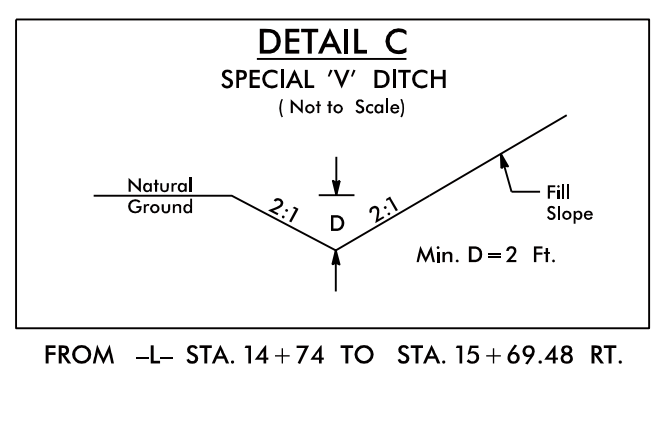
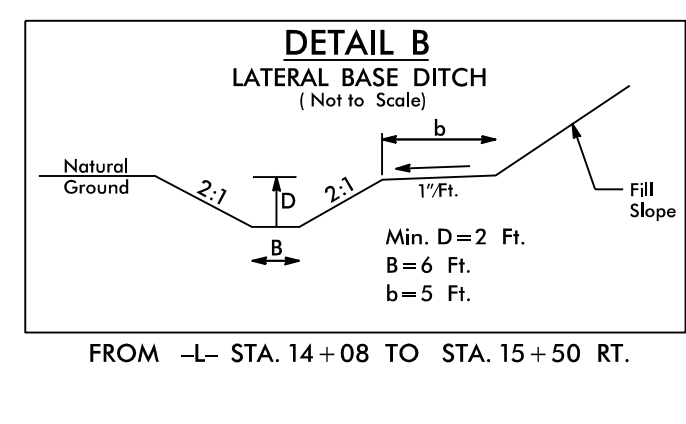
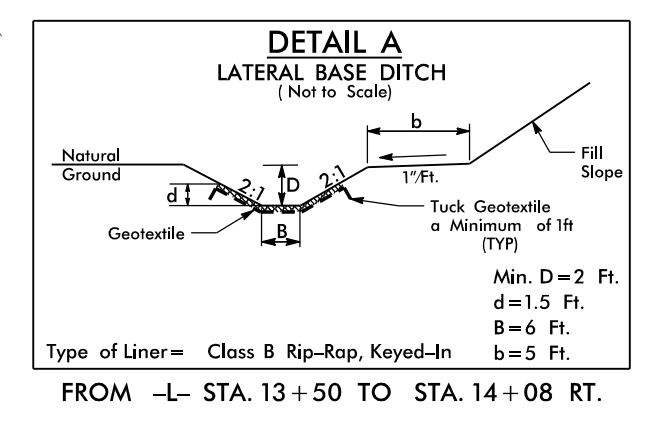

FOR -L- PROFILE SEE SHEET 5
FOR -DW1- PROFILE SEE SHEET 5

REVISIONS

PLANTING DETAILS

SEEDLING / LINER BAREROOT PLANTING DETAIL

HEALING IN

1. Locate a healing-in site in a shady, well protected area.
2. Excavate a flat bottom trench 12 inches deep and provide drainage.

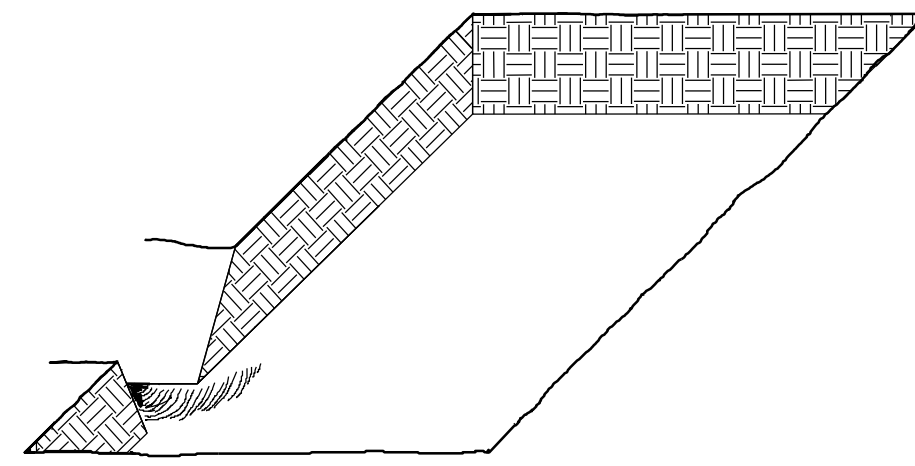

3. Backfill the trench with 2 inches well rotted sawdust. Place a 2 inch layer of well rotted sawdust at a sloping angle at one end of the trench.

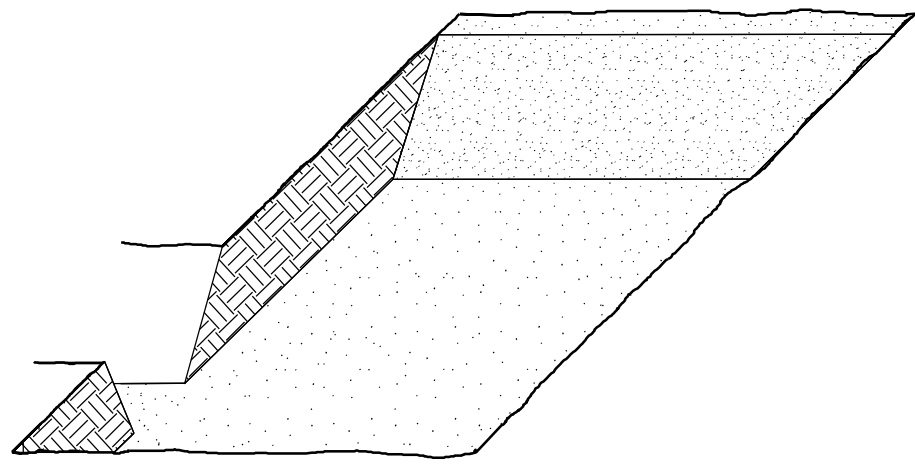

4. Place a single layer of plants against the sloping end so that the root collar is at ground level.

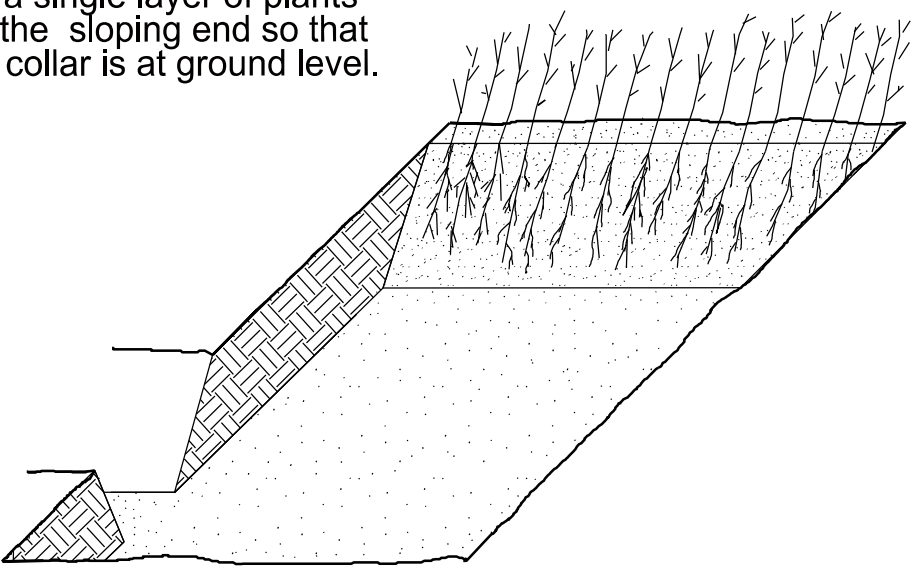

5. Place a 2 inch layer of well rotted sawdust over the roots maintaining a sloping angle.

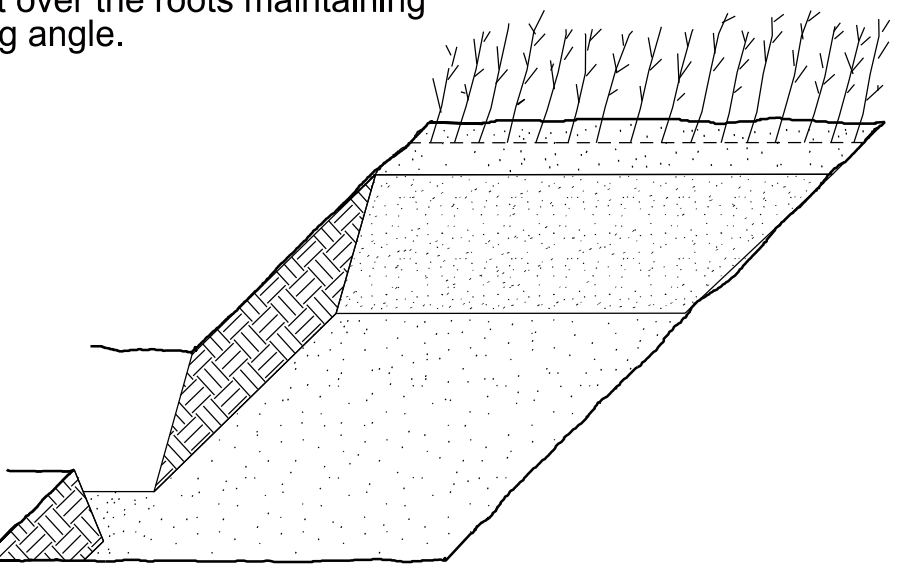

6. Repeat layers of plants and sawdust as necessary and water thoroughly.

DIBBLE PLANTING METHOD USING THE KBC PLANTING BAR

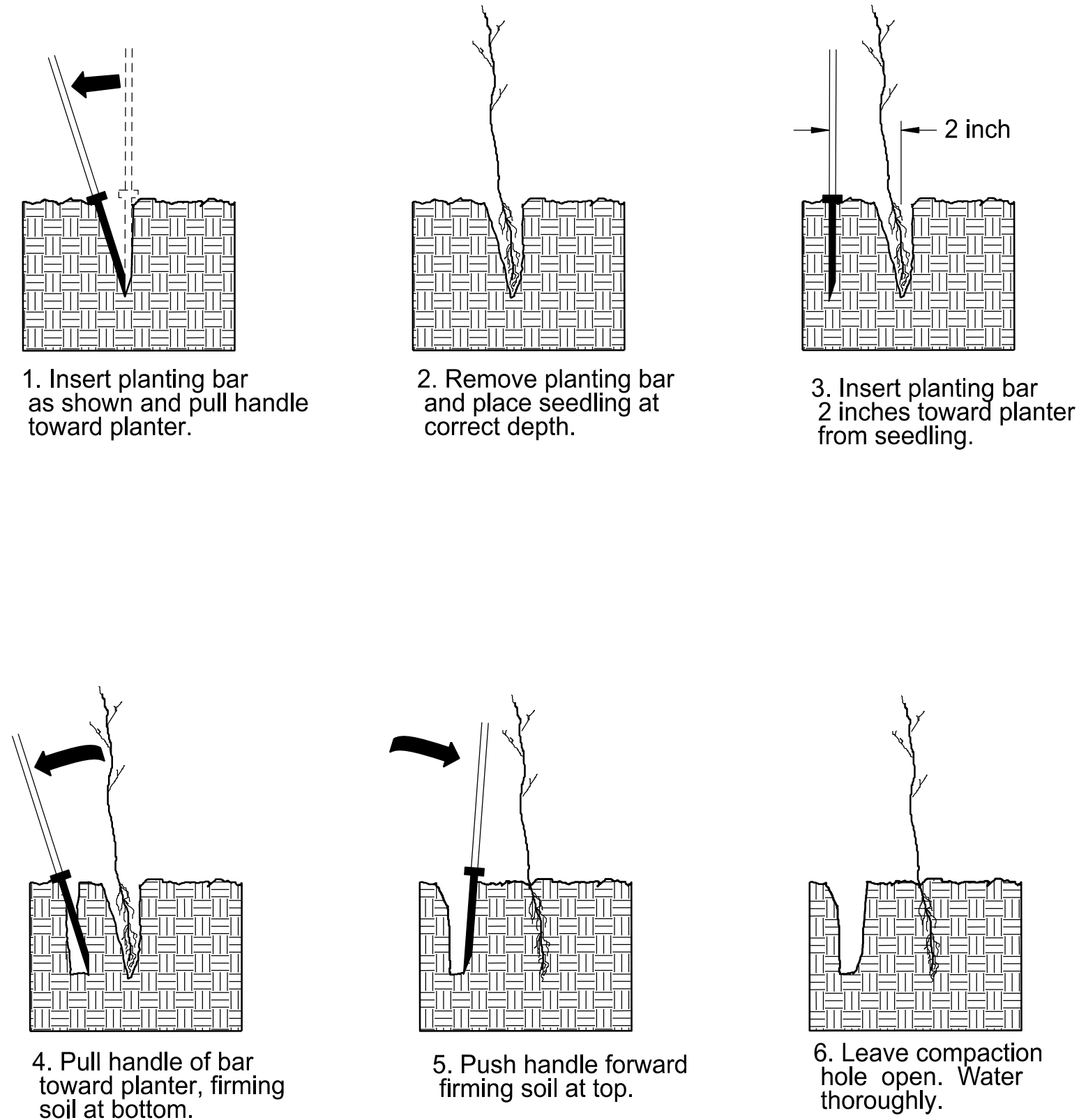

PLANTING NOTES:

PLANTING BAG
During planting, seedlings shall be kept in a moist canvas bag or similar container to prevent the root systems from drying.



KBC PLANTING BAR
Planting bar shall have a blade with a triangular cross section, and shall be 12 inches long, 4 inches wide and 1 inch thick at center.

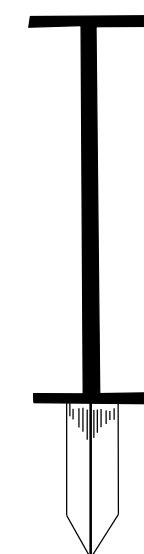

ROOT PRUNING
All seedlings shall be root pruned, if necessary, so that no roots extend more than 10 inches below the root collar.

REFORESTATION

- TREE REFORESTATION SHALL BE PLANTED 6 FT. TO 10 FT. ON CENTER, RANDOM SPACING, AVERAGING 8 FT. ON CENTER, APPROXIMATELY 680 PLANTS PER ACRE.

REFORESTATION

MIXTURE, TYPE, SIZE, AND FURNISH SHALL CONFORM TO THE FOLLOWING:

34% LIRIODENDRON TULIPIFERA	TULIP POPLAR	12 in - 18 in BR
33% PLATANUS OCCIDENTALIS	AMERICAN SYCAMORE	12 in - 18 in BR
33% BETULA NIGRA	RIVER BIRCH	12 in - 18 in BR

REFORESTATION DETAIL SHEET

N.C.D.O.T. - ROADSIDE ENVIRONMENTAL UNIT

STATE OF NORTH CAROLINA
DEPARTMENT OF TRANSPORTATION

SIGNING PLAN
MACON COUNTY

LOCATION: REPLACE BRIDGE NO. 55055 ON SR 1679 (PEEKS CREEK RD)
OVER CULLASAJA RIVER

ROADWAY STANDARD DRAWING

THE FOLLOWING ROADWAY STANDARDS AS APPEAR IN "ROADWAY STANDARD DRAWINGS" - PROJECT SERVICES UNIT - N.C. DEPARTMENT OF TRANSPORTATION - RALEIGH, N.C., DATED JANUARY 2024 ARE APPLICABLE TO THIS PROJECT AND BY REFERENCE HEREBY ARE CONSIDERED A PART OF THESE PLANS:

STD. NO.	TITLE
903.10	GROUND MOUNTED SIGN SUPPORTS
904.10	ORIENTATION OF GROUND MOUNTED SIGNS
904.50	MOUNTING OF TYPE 'D', 'E' AND 'F' SIGNS ON 'U' CHANNEL POSTS

GENERAL NOTES

- . SIGNS FURNISHED BY STATE
- . CONFIRM IN WRITING AT LEAST 4 MONTHS IN ADVANCE, THE ACTUAL DATE THE DEPARTMENT FURNISHED SIGNS WILL BE REQUIRED.
- . ALL TYPE 'D' SIGNS SHALL BE MOUNTED ON TWO U-CHANNEL POSTS UNLESS OTHERWISE INDICATED ON THE PLANS.
- . IF REMOVAL OR RELOCATION OF SIGNS ON PRIVATE STREET (NON-STATE MAINTAINED) IS REQUIRED DUE TO CONSTRUCTION, THE CONTRACTOR SHALL INFORM THE ENGINEER. THE WORK WILL BE COMPLETED BY OTHERS.
- . ALL EXISTING SIGNS ON "U" CHANNEL POST WITHIN THE PROJECT LIMITS SHALL BE REMOVED AND DISPOSED OF UNLESS OTHERWISE NOTED ON PLANS.
- . SEE ROADWAY PLANS FOR GUARD/GUIDE RAIL DETAILS.

SUMMARY OF QUANTITIES

ITEM NO.		ITEM DESCRIPTION	QUANTITY	UNIT
DESC. NO.	SECT. NO.			
4072000000	903	SUPPORTS, 3 LB STEEL U-CHANNEL	28	L.F.
4096000000	904	SIGN ERECTION, TYPE D	2	EA.
4155000000	907	DISPOSAL OF SIGN SYSTEM, U-CHANNEL	2	EA.

INDEX

SHEET NO.	DESCRIPTION
SIGN-1	TITLE SHEET
SIGN-2	SIGN DESIGN
SIGN-3	SIGNING PLAN

PLANS PREPARED BY: DRMP, INC.

TIMOTHY A. KLOTZ, P.E. PROJECT MANAGER
ERIC H. ALSPOUGH, E.I. PROJECT ENGINEER



HB-0030

SIGN 1

NORTH CAROLINA DEPARTMENT OF TRANSPORTATION

APPROVED: Timothy A. Klotz

DATE: 10/7/2025

SEAL:



DOCUMENT NOT CONSIDERED FINAL UNLESS ALL SIGNATURES COMPLETED

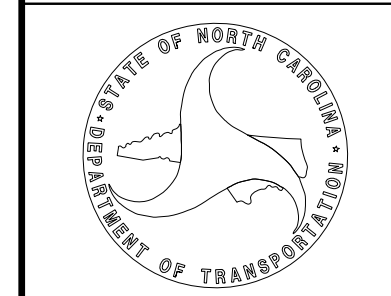

T.I.P.: HB-0030

CONTRACT: DN01129

